

FLASH MEMORY

CMOS

128 M (16M × 8/8M × 16) BIT

MirrorFlash™*

MBM29PL12LM 10

DESCRIPTION

The MBM29PL12LM is a 128M-bit, 3.0 V-only Flash memory organized as 16M bytes by 8 bits or 8M words by 16 bits. The MBM29PL12LM is offered in 58-pin TSOP (1) and 80-ball FBGA. The device is designed to be programmed in-system with the standard 3.0 V V_{CC} supply. 12.0 V V_{PP} and 5.0 V V_{CC} are not required for write or erase operations. The devices can also be reprogrammed in standard EPROM programmers.

(Continued)

PRODUCT LINE UP

Part No.	MBM29PL12LM
	10
V_{CC}	3.0 V to 3.6 V
Max Address Access Time	100 ns
Max \overline{CE} Access Time	100 ns
Max Page Read Access Time	30 ns

Notes : • Programming in byte mode (× 8) is prohibited.
 • Programming to the address that already contains data is prohibited.
 (It is mandatory to erase data prior to overprogram on the same address.)

PACKAGES

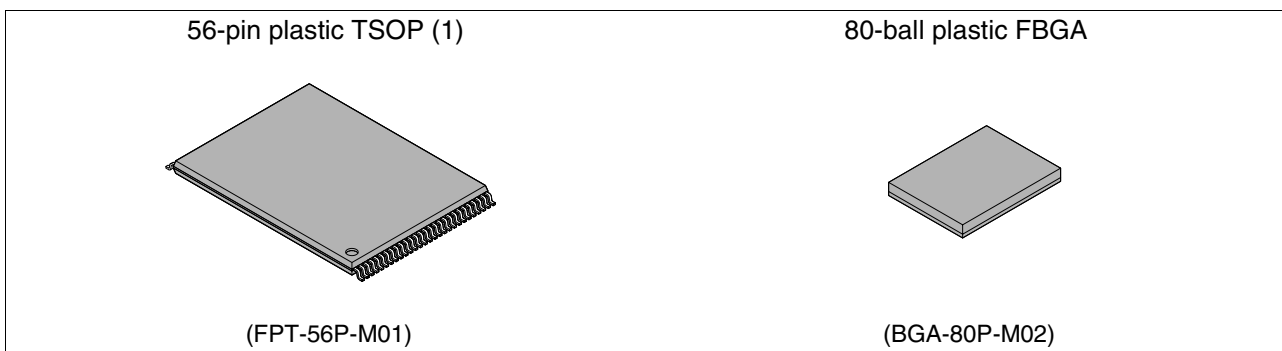

* : MirrorFlash™ is a trademark of Fujitsu Limited.

MBM29PL12LM₁₀

(Continued)

The standard MBM29PL12LM offers access times of 90 ns, allowing operation of high-speed microprocessors without wait states. To eliminate bus contention the devices have separate chip enable (\overline{CE}), write enable (\overline{WE}), and output enable (\overline{OE}) controls.

The MBM29PL12LM supports command set compatible with JEDEC single-power-supply EEPROMS standard. Commands are written into the command register. The register contents serve as input to an internal state-machine which controls the erase and programming circuitry. Write cycles also internally latch addresses and data needed for the programming and erase operations. Reading data out of the devices is similar to reading from 5.0 V and 12.0 V Flash or EPROM devices.

The MBM29PL12LM is programmed by executing the program command sequence. This will invoke the Embedded Program Algorithm™ which is an internal algorithm that automatically times the program pulse widths and verifies proper cell margin. Erase is accomplished by executing the erase command sequence. This will invoke the Embedded Erase Algorithm™ which is an internal algorithm that automatically preprograms the array if it is not already programmed before executing the erase operation. During erase, the device automatically times the erase pulse widths and verifies proper cell margin.

The device also features a sector erase architecture. The sector mode allows each sector to be erased and reprogrammed without affecting other sectors. All sectors are erased when shipped from the factory.

The device features single 3.0 V power supply operation for both read and write functions. Internally generated and regulated voltages are provided for the program and erase operations. A low V_{CC} detector automatically inhibits write operations on the loss of power. The end of program or erase is detected by Data Polling of DQ_7 , by the Toggle Bit feature on DQ_6 . Once the end of a program or erase cycle has been completed, the devices internally return to the read mode.

Fujitsu Flash technology combines years of Flash memory manufacturing experience to produce the highest levels of quality, reliability, and cost effectiveness. The devices electrically erase all bits within a sector simultaneously via hot-hole assisted erase. The words are programmed one word at a time using the EPROM programming mechanism of hot electron injection.

■ FEATURES

- **0.23 μ m Process Technology**
- **Single 3.0 V read, program and erase**
Minimizes system level power requirements
- **Industry-standard pinouts**
56-pin TSOP (1)
80-ball FBGA (Package suffix: PBT)
- **Minimum 100,000 program/erase cycles**
- **High performance Page mode**
Fast 8 bytes / 4 words access capability
- **Sector erase architecture**
256 \times 64K byte and 32K word sectors
Any combination of sectors can be concurrently erased. Also supports full chip erase
- **HiddenROM**
256 bytes / 128 words of HiddenROM, accessible through a “HiddenROM Entry” command sequence
Factory serialized and protected to provide a secure electronic serial number (ESN)
- **WP/ACC input pin**
At V_{IL} , allows protection of outermost two 8K bytes / 4K words sectors, regardless of sector protection/unprotection status
At V_{ACC} , increases program performance
- **Embedded Erase^{TM*} Algorithms**
Automatically pre-programs and erases the chip or any sector
- **Embedded Program^{TM*} Algorithms**
Automatically writes and verifies data at specified address
- **Data Polling and Toggle Bit feature for detection of program or erase cycle completion**
- **Ready/Busy output (RY/BY)**
Hardware method for detection of program or erase cycle completion
- **Automatic sleep mode**
When addresses remain stable, automatically switches themselves to low power mode
- **Erase Suspend/Resume**
Suspends the erase operation to allow a read data and/or program in another sector within the same device
- **Low V_{CC} write inhibit ≤ 2.5 V**
- **Sector Group Protection**
Hardware method disables any combination of sector groups from program or erase operations
- **Sector Group Protection Set function by Extended sector protect command**
- **Fast Programming Function by Extended Command**
- **Temporary sector group unprotection**
Temporary sector group unprotection via the \overline{RESET} pin
This feature allows code changes in previously locked sectors
- **In accordance with CFI (Common Flash Memory Interface)**

*: Embedded EraseTM and Embedded ProgramTM are trademarks of Advanced Micro Devices, Inc.

MBM29PL12LM₁₀

■ PIN ASSIGNMENTS

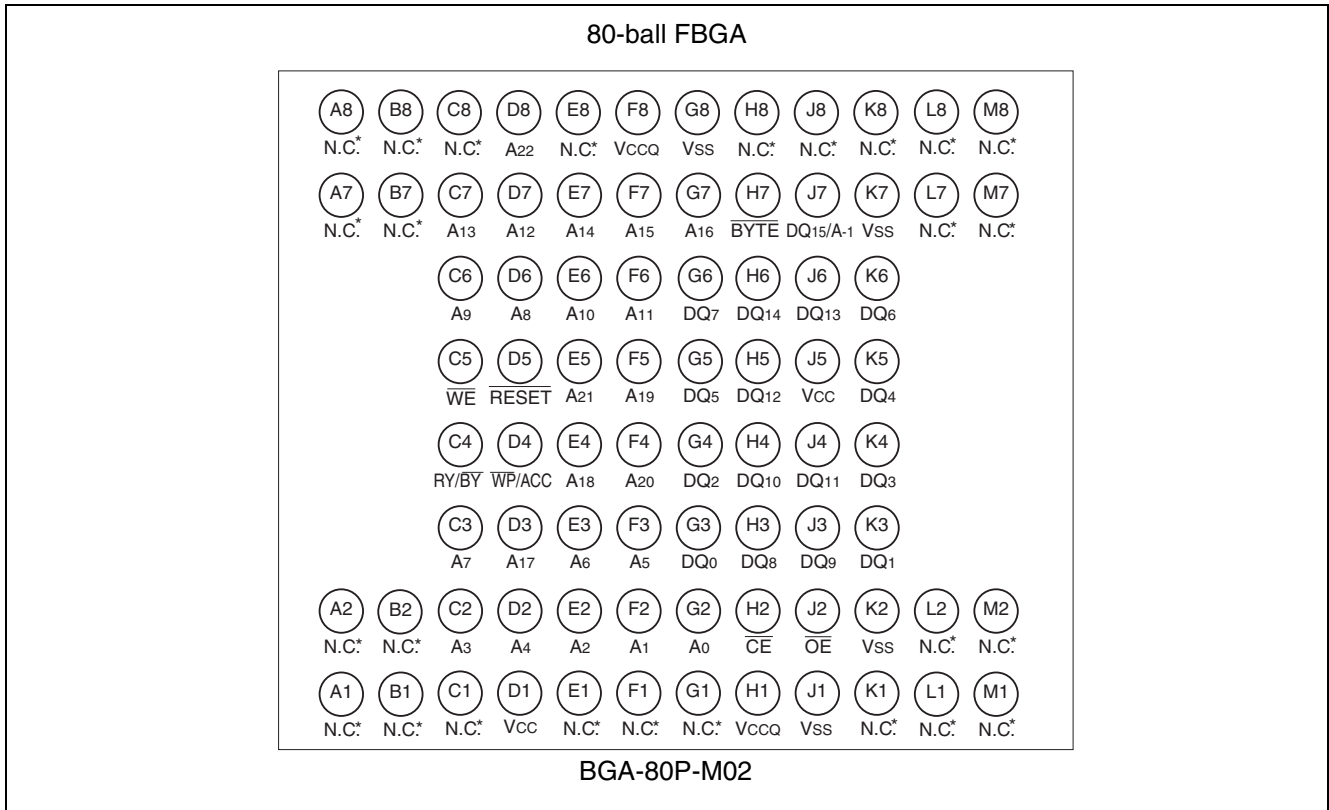
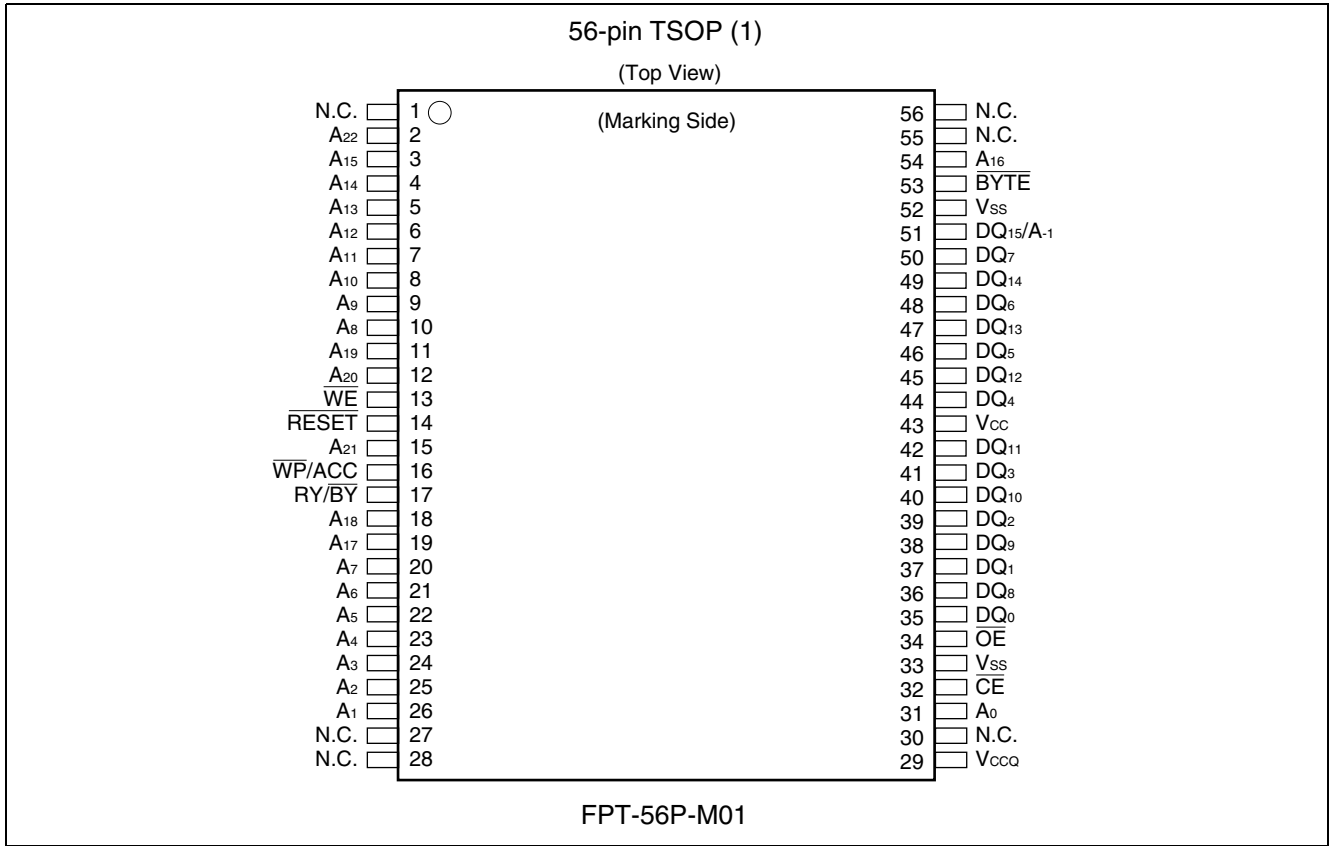

■ PIN DESCRIPTIONS

MBM29PL12LM Pin Configuration

Pin	Function
A ₂₂ to A ₀ , A ₋₁	Address Inputs
DQ ₁₅ to DQ ₀	Data Inputs/Outputs
$\overline{\text{CE}}$	Chip Enable
$\overline{\text{OE}}$	Output Enable
$\overline{\text{WE}}$	Write Enable
$\overline{\text{WP/ACC}}$	Hardware Write Protection/Program Acceleration
$\overline{\text{RESET}}$	Hardware Reset Pin/Temporary Sector Group Unprotection
$\overline{\text{BYTE}}$	Select 8-bit or 16-bit mode
RY/ $\overline{\text{BY}}$	Ready/Busy Output
V _{CC}	Device Power Supply
V _{CCQ}	Output Voltage
V _{SS}	Device Ground
N.C.	No Internal Connection

MBM29PL12LM₁₀

■ BLOCK DIAGRAM

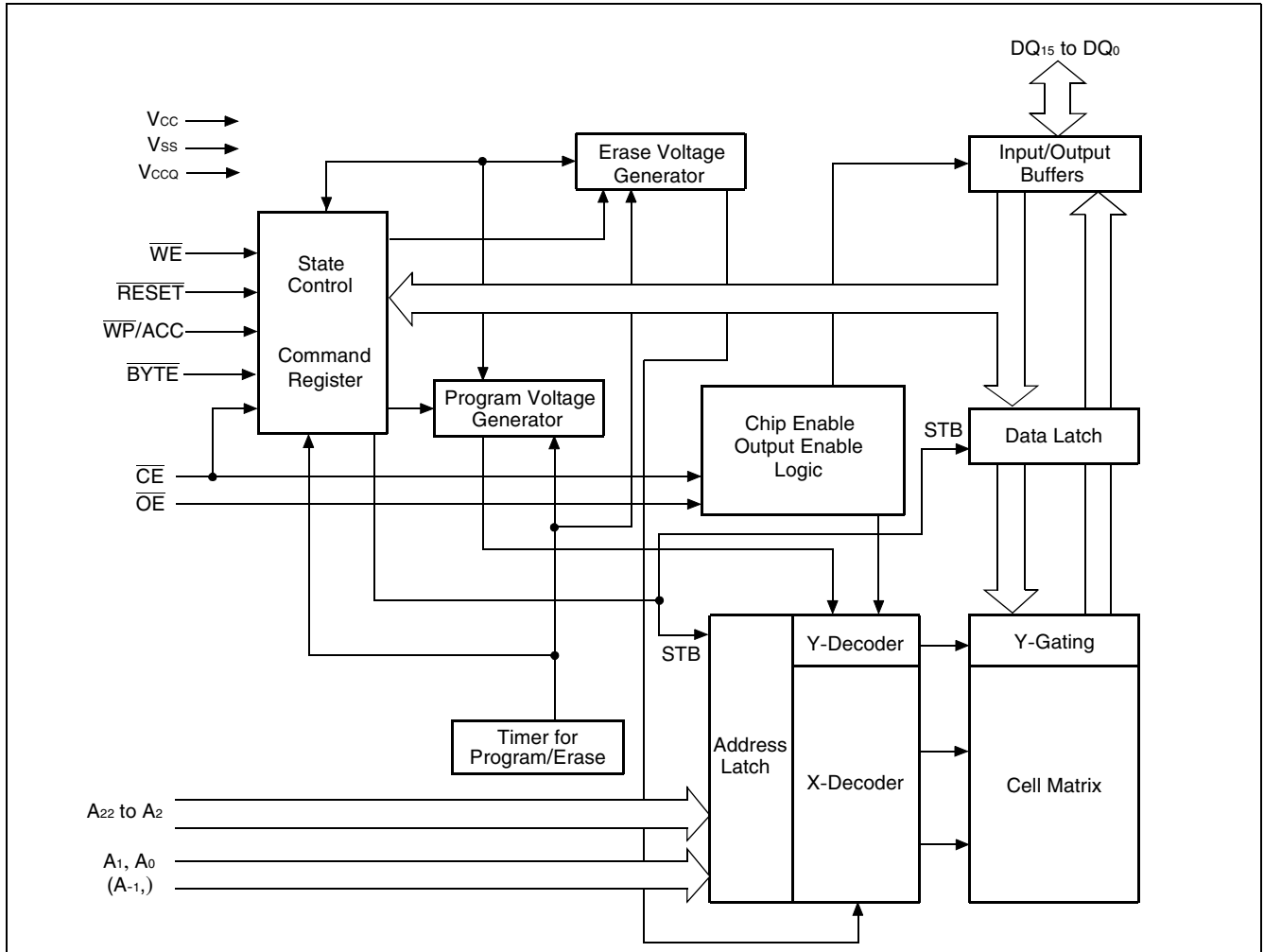

■ LOGIC SYMBOL

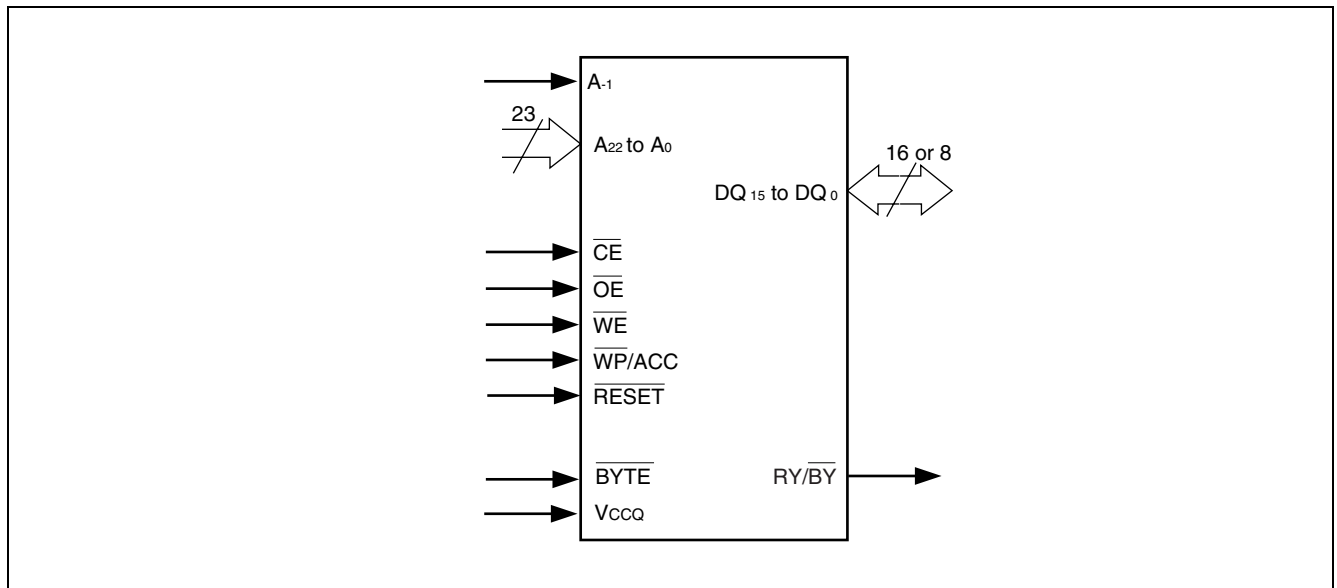

■ DEVICE BUS OPERATION

MBM29PL12LM User Bus Operations (Word Mode : $\overline{\text{BYTE}} = V_{IH}$)

Operation	$\overline{\text{CE}}$	$\overline{\text{OE}}$	$\overline{\text{WE}}$	A ₀	A ₁	A ₂	A ₃	A ₆	A ₉	DQ ₀ to DQ ₁₅	$\overline{\text{RESET}}$	$\overline{\text{WP/ACC}}$
Standby	H	X	X	X	X	X	X	X	X	Hi-Z	H	X
Autoselect Manufacture Code* ¹	L	L	H	L	L	L	L	L	V _{ID}	Code	H	X
Autoselect Device Code* ¹	L	L	H	H	L	L	L	L	V _{ID}	Code	H	X
Read	L	L	H	A ₀	A ₁	A ₂	A ₃	A ₆	A ₉	D _{OUT}	H	X
Output Disable	L	H	H	X	X	X	X	X	X	Hi-Z	H	X
Write (Program/Erase)	L	H	L	A ₀	A ₁	A ₂	A ₃	A ₆	A ₉	* ⁴	H	* ⁵
Enable Sector Group Protection* ²	L	H	L	L	H	L	L	L	X	* ⁴	V _{ID}	H
Temporary Sector Group Unprotection	X	X	X	X	X	X	X	X	X	* ⁴	V _{ID}	H
Reset (Hardware)	X	X	X	X	X	X	X	X	X	Hi-Z	L	X
Sector Write Protection* ³	X	X	X	X	X	X	X	X	X	X	H	L

Legend : L = V_{IL}, H = V_{IH}, X = V_{IL} or V_{IH}. See DC Characteristics for voltage levels.
Hi-Z = High-Z, V_{ID} = 11.5 to 12.5V

- *1 : Manufacturer and device codes may also be accessed via a command register write sequence. See "MBM29PL12LM Standard Command Definitions".
- *2 : Refer to Sector Group Protection.
- *3 : Protects the first 32K words sector (SA0)
- *4 : D_{IN} or D_{OUT} as required by command sequence, data polling, or sector protect algorithm
- *5 : If $\overline{\text{WP/ACC}} = V_{IL}$, the first sector remain protected.
If $\overline{\text{WP/ACC}} = V_{IH}$, the first sector will be protected or unprotected as determined by the method specified in "Sector Group Protection".

MBM29PL12LM₁₀

MBM29PL12LM User Bus Operations (Byte Mode : $\overline{\text{BYTE}} = V_{IL}$)

Operation	$\overline{\text{CE}}$	$\overline{\text{OE}}$	$\overline{\text{WE}}$	DQ ₁₅ / A ₋₁	A ₀	A ₁	A ₂	A ₃	A ₆	A ₉	DQ ₀ to DQ ₇	$\overline{\text{RESET}}$	WP/ ACC
Standby	H	X	X	X	X	X	X	X	X	X	Hi-Z	H	X
Autoselect Manufacture Code* ¹	L	L	H	L	L	L	L	L	L	V _{ID}	Code	H	X
Autoselect Device Code* ¹	L	L	H	L	H	L	L	L	L	V _{ID}	Code	H	X
Read	L	L	H	A ₋₁	A ₀	A ₁	A ₂	A ₃	A ₆	A ₉	D _{OUT}	H	X
Output Disable	L	H	H	X	X	X	X	X	X	X	Hi-Z	H	X
Write (Erase)	L	H	L	A ₋₁	A ₀	A ₁	A ₂	A ₃	A ₆	A ₉	*4	H	*5
Enable Sector Group Protection* ²	L	H	L	L	L	H	L	L	L	X	*4	V _{ID}	H
Temporary Sector Group Unprotection	X	X	X	X	X	X	X	X	X	X	*4	V _{ID}	H
Reset (Hardware)	X	X	X	X	X	X	X	X	X	X	Hi-Z	L	X
Sector Write Protection* ³	X	X	X	X	X	X	X	X	X	X	X	H	L

Legend : L = V_{IL}, H = V_{IH}, X = V_{IL} or V_{IH}. See DC Characteristics for voltage levels.
Hi-Z = High-Z, V_{ID} = 11.5 to 12.5V

*1 : Manufacturer and device codes may also be accessed via a command register write sequence.
See "MBM29PL12LM Standard Command Definitions".

*2 : Refer to Sector Group Protection.

*3 : Protects the first 64K bytes sectors

*4 : D_{IN} or D_{OUT} as required by command sequence, data polling, or sector protect algorithm

*5 : If $\overline{\text{WP/ACC}} = V_{IL}$, the first sector remain protected.
If $\overline{\text{WP/ACC}} = V_{IH}$, the first sector will be protected or unprotected as determined by the method specified in "Sector Group Protection".

MBM29PL12LM Standard Command Definitions*1

Command Sequence		Bus Write Cycles Req'd	First Bus Write Cycle		Second Bus Write Cycle		Third Bus Write Cycle		Fourth Bus Read/Write Cycle		Fifth Bus Write Cycle		Sixth Bus Write Cycle	
			Addr	Data	Addr	Data	Addr	Data	Addr	Data	Addr	Data	Addr	Data
Reset*2	Word/Byte	1	XXXh	F0h	—	—	—	—	—	—	—	—	—	—
Reset*2	Word	3	555h	AAh	2AAh	55h	555h	F0h	RA*13	RD*13	—	—	—	—
	Byte		AAAh		555h		AAAh							
Autoselect (Device ID)	Word	3	555h	AAh	2AAh	55h	555h	90h	00h*13	04h*13	—	—	—	—
	Byte		AAAh		555h		AAAh							
Program	Word	4	555h	AAh	2AAh	55h	555h	A0h	PA	PD	—	—	—	—
Chip Erase	Word	6	555h	AAh	2AAh	55h	555h	80h	555h	AAh	2AAh	55h	555h	10h
	Byte		AAAh		555h		AAAh		555h		AAAh			
Sector Erase	Word	6	555h	AAh	2AAh	55h	555h	80h	555h	AAh	2AAh	55h	SA	30h
	Byte		AAAh		555h		AAAh		555h		AAAh			
Program/Erase Suspend*3		1	XXXh	B0h	—	—	—	—	—	—	—	—	—	—
Program/Erase Resume*3		1	XXXh	30h	—	—	—	—	—	—	—	—	—	—
Set to Fast Mode*4	Word	3	555h	AAh	2AAh	55h	555h	20h	—	—	—	—	—	—
	Byte		AAAh		555h		AAAh							
Fast Program*4	Word	2	XXXh	A0h	PA	PD	—	—	—	—	—	—	—	—
Reset from Fast Mode*5	Word/Byte	2	XXXh	90h	XXXh	00h*12	—	—	—	—	—	—	—	—
Write to Buffer	Word	20	555h	AAh	2AAh	55h	SA	25h	SA	0Fh	PA	PD	WBL	PD
	Byte		AAAh		555h		SA		AAAh					
Program Buffer to Flash (Confirm)		1	SA	29h	—	—	—	—	—	—	—	—	—	—
Write to Buffer Abort Reset*6	Word	3	555h	AAh	2AAh	55h	555h	F0h	—	—	—	—	—	—
	Byte		AAAh		555h		AAAh							
Extended Sector Group Protection*7,*8	Word	4	XXXh	60h	SGA	60h	SGA	40h	SGA*13	SD*13	—	—	—	—
	Byte		XXXh		60h		SGA		40h					
Query*9	Word	1	55h	98h	—	—	—	—	—	—	—	—	—	—
	Byte		AAh		98h		—							
HiddenROM Entry*10	Word	3	555h	AAh	2AAh	55h	555h	88h	—	—	—	—	—	—
	Byte		AAAh		555h		AAAh							
HiddenROM Program*10,*11	Word	4	555h	AAh	2AAh	55h	555h	A0h	PA	PD	—	—	—	—
	Byte		AAAh		555h		AAAh							
HiddenROM Exit*11	Word	4	555h	AAh	2AAh	55h	555h	90h	XXXh	00h	—	—	—	—
	Byte		AAAh		555h		AAAh							

(Continued)

MBM29PL12LM₁₀

(Continued)

Legend : Address bits A_{22} to $A_{15} = X = \text{“H”}$ or “L” for all address commands except for Program Address (PA), Sector Address (SA) and Sector Group Address (SGA).
Bus operations are defined in “MBM29PL12LM User Bus Operations (Word Mode : BYTE = V_{IH})” and “MBM29PL12LM User Bus Operations (Byte Mode : BYTE = V_{IL})”.

RA = Address of the memory location to be read.
PA = Address of the memory location to be programmed. Addresses are latched on the falling edge of the write pulse.
SA = Address of the sector to be programmed / erased. The combination of A_{22} , A_{21} , A_{20} , A_{19} , A_{18} , A_{17} , A_{16} , and A_{15} will uniquely select any sector. See “Sector Address Table (MBM29PL12LM)”.

SGA = Sector Group Address to be protected. See “Sector Group Address Table (MBM29PL12LM)”.

RD = Data read from location RA during read operation.
PD = Data to be programmed at location PA. Data is latched on the rising edge of write plus.
WBL = Write Buffer Location
HRA = Address of the HiddenROM area ;
Word Mode : 000000h to 000007h
Byte Mode : 000000h to 0000FFh

- *1 : The command combinations not described in “MBM29PL12LM Standard Command Definitions” are illegal.
- *2 : Both of these reset commands are equivalent except for "Write to Buffer Abort Reset".
- *3 : The Erase Suspend and Erase Resume command are valid only during a sector erase operation.
- *4 : The Set to Fast Mode command is required prior to the Fast Program command.
- *5 : The Reset from Fast Mode command is required to return to the read mode when the device is in fast mode.
- *6 : Reset to the read mode. The Write to Buffer Abort Reset command is required after the Write to Buffer operation was aborted.
- *7 : This command is valid while $\overline{\text{RESET}} = V_{ID}$.
- *8 : Sector Group Address (SGA) with $A_6 = 0$, $A_3 = 0$, $A_2 = 0$, $A_1 = 1$, and $A_0 = 0$
- *9 : The valid address are A_6 to A_0 .
- *10 : The HiddenROM Entry command is required prior to the HiddenROM programming.
- *11 : This command is valid during HiddenROM mode.
- *12 : The data “F0h” is also acceptable.
- *13 : Indicates read cycle.

Sector Group Protection Verify Autoselect Codes

Type		A ₂₂ to A ₁₅	A ₆	A ₃	A ₂	A ₁	A ₀	A ₋₁ *1	Code (HEX)
Manufacturer's Code		X	V _{IL}	V _{IL}	V _{IL}	V _{IL}	V _{IL}	V _{IL}	04h
Device Code	Word	X	V _{IL}	V _{IL}	V _{IL}	V _{IL}	V _{IH}	X	227Eh
	Byte							V _{IL}	7Eh
Extended Device Code*2	Word	X	V _{IL}	V _{IH}	V _{IH}	V _{IH}	V _{IL}	X	2212h
	Byte							V _{IL}	12h
	Word	X	V _{IL}	V _{IH}	V _{IH}	V _{IH}	V _{IH}	X	2200h
	Byte							V _{IL}	00h
Sector Group Protection*4		Sector Group Addresses	V _{IL}	V _{IL}	V _{IL}	V _{IH}	V _{IL}	V _{IL}	*3

*1 : A₋₁ is for Byte mode.

*2 : At Word mode, a read cycle at address 01h (at Byte mode, 02h) outputs device code. When 227Eh (at Byte mode, 7Eh) is output, it indicates that reading two additional codes, called Extended Device Codes, will be required. Therefore the system may continue reading out these Extended Device Codes at the address of 0Eh (at Byte mode, 1Ch), as well as at 0Fh (at Byte mode, 1Eh).

*3 : Outputs 01h at protected sector group addresses and outputs 00h at unprotected sector group addresses.

*4 : At $\overline{CE} = \text{Fix}$, designate SGA as (A₆, A₃, A₂, A₁, A₀) = (0, 0, 0, 1, 0) , with an interval of one cycle after \overline{WE} rising (the last write command) .

MBM29PL12LM₁₀

Sector Address Table (MBM29PL12LM)

Sector	A ₂₂	A ₂₁	A ₂₀	A ₁₉	A ₁₈	A ₁₇	A ₁₆	A ₁₅	Sector size (Kbytes/ Kwords)	(×8) Address Range	(×16) Address Range
SA0	0	0	0	0	0	0	0	0	64/32	000000h to 00FFFFh	000000h to 007FFFh
SA1	0	0	0	0	0	0	0	1	64/32	010000h to 01FFFFh	008000h to 00FFFFh
SA2	0	0	0	0	0	0	1	0	64/32	020000h to 02FFFFh	010000h to 017FFFh
SA3	0	0	0	0	0	0	1	1	64/32	030000h to 03FFFFh	018000h to 01FFFFh
SA4	0	0	0	0	0	1	0	0	64/32	040000h to 04FFFFh	020000h to 027FFFh
SA5	0	0	0	0	0	1	0	1	64/32	050000h to 05FFFFh	028000h to 02FFFFh
SA6	0	0	0	0	0	1	1	0	64/32	060000h to 06FFFFh	030000h to 037FFFh
SA7	0	0	0	0	0	1	1	1	64/32	070000h to 07FFFFh	038000h to 03FFFFh
SA8	0	0	0	0	1	0	0	0	64/32	080000h to 08FFFFh	040000h to 047FFFh
SA9	0	0	0	0	1	0	0	1	64/32	090000h to 09FFFFh	048000h to 04FFFFh
SA10	0	0	0	0	1	0	1	0	64/32	0A0000h to 0AFFFFh	050000h to 057FFFh
SA11	0	0	0	0	1	0	1	1	64/32	0B0000h to 0BFFFFh	058000h to 05FFFFh
SA12	0	0	0	0	1	1	0	0	64/32	0C0000h to 0CFFFFh	060000h to 067FFFh
SA13	0	0	0	0	1	1	0	1	64/32	0D0000h to 0DFFFFh	068000h to 06FFFFh
SA14	0	0	0	0	1	1	1	0	64/32	0E0000h to 0EFFFFh	070000h to 077FFFh
SA15	0	0	0	0	1	1	1	1	64/32	0F0000h to 0FFFFFFh	078000h to 07FFFFh
SA16	0	0	0	1	0	0	0	0	64/32	100000h to 10FFFFh	080000h to 087FFFh
SA17	0	0	0	1	0	0	0	1	64/32	110000h to 11FFFFh	088000h to 08FFFFh
SA18	0	0	0	1	0	0	1	0	64/32	120000h to 12FFFFh	090000h to 097FFFh
SA19	0	0	0	1	0	0	1	1	64/32	130000h to 13FFFFh	098000h to 09FFFFh
SA20	0	0	0	1	0	1	0	0	64/32	140000h to 14FFFFh	0A0000h to 0A7FFFh
SA21	0	0	0	1	0	1	0	1	64/32	150000h to 15FFFFh	0A8000h to 0AFFFFh
SA22	0	0	0	1	0	1	1	0	64/32	160000h to 16FFFFh	0B0000h to 0B7FFFh
SA23	0	0	0	1	0	1	1	1	64/32	170000h to 17FFFFh	0B8000h to 0BFFFFh
SA24	0	0	0	1	1	0	0	0	64/32	180000h to 18FFFFh	0C0000h to 0C7FFFh
SA25	0	0	0	1	1	0	0	1	64/32	190000h to 19FFFFh	0C8000h to 0CFFFFh
SA26	0	0	0	1	1	0	1	0	64/32	1A0000h to 1AFFFFh	0D0000h to 0D7FFFh
SA27	0	0	0	1	1	0	1	1	64/32	1B0000h to 1BFFFFh	0D8000h to 0DFFFFh
SA28	0	0	0	1	1	1	0	0	64/32	1C0000h to 1CFFFFh	0E0000h to 0E7FFFh
SA29	0	0	0	1	1	1	0	1	64/32	1D0000h to 1DFFFFh	0E8000h to 0EFFFFh
SA30	0	0	0	1	1	1	1	0	64/32	1E0000h to 1EFFFFh	0F0000h to 0F7FFFh

(Continued)

Sector	A ₂₂	A ₂₁	A ₂₀	A ₁₉	A ₁₈	A ₁₇	A ₁₆	A ₁₅	Sector size (Kbytes/ Kwords)	(×8) Address Range	(×16) Address Range
SA31	0	0	0	1	1	1	1	1	64/32	1F0000h to 1FFFFFFh	0F8000h to 0FFFFFFh
SA32	0	0	1	0	0	0	0	0	64/32	200000h to 20FFFFh	100000h to 107FFFh
SA33	0	0	1	0	0	0	0	1	64/32	210000h to 21FFFFh	108000h to 10FFFFh
SA34	0	0	1	0	0	0	1	0	64/32	220000h to 22FFFFh	110000h to 117FFFh
SA35	0	0	1	0	0	0	1	1	64/32	230000h to 23FFFFh	118000h to 11FFFFh
SA36	0	0	1	0	0	1	0	0	64/32	240000h to 24FFFFh	120000h to 127FFFh
SA37	0	0	1	0	0	1	0	1	64/32	250000h to 25FFFFh	128000h to 12FFFFh
SA38	0	0	1	0	0	1	1	0	64/32	260000h to 26FFFFh	130000h to 137FFFh
SA39	0	0	1	0	0	1	1	1	64/32	270000h to 27FFFFh	138000h to 13FFFFh
SA40	0	0	1	0	1	0	0	0	64/32	280000h to 28FFFFh	140000h to 147FFFh
SA41	0	0	1	0	1	0	0	1	64/32	290000h to 29FFFFh	148000h to 14FFFFh
SA42	0	0	1	0	1	0	1	0	64/32	2A0000h to 2AFFFFh	150000h to 157FFFh
SA43	0	0	1	0	1	0	1	1	64/32	2B0000h to 2BFFFFh	158000h to 15FFFFh
SA44	0	0	1	0	1	1	0	0	64/32	2C0000h to 2CFFFFh	160000h to 167FFFh
SA45	0	0	1	0	1	1	0	1	64/32	2D0000h to 2DFFFFh	168000h to 16FFFFh
SA46	0	0	1	0	1	1	1	0	64/32	2E0000h to 2EFFFFh	170000h to 177FFFh
SA47	0	0	1	0	1	1	1	1	64/32	2F0000h to 2FFFFFFh	178000h to 17FFFFh
SA48	0	0	1	1	0	0	0	0	64/32	300000h to 30FFFFh	180000h to 187FFFh
SA49	0	0	1	1	0	0	0	1	64/32	310000h to 31FFFFh	188000h to 18FFFFh
SA50	0	0	1	1	0	0	1	0	64/32	320000h to 32FFFFh	190000h to 197FFFh
SA51	0	0	1	1	0	0	1	1	64/32	330000h to 33FFFFh	198000h to 19FFFFh
SA52	0	0	1	1	0	1	0	0	64/32	340000h to 34FFFFh	1A0000h to 1A7FFFh
SA53	0	0	1	1	0	1	0	1	64/32	350000h to 35FFFFh	1A8000h to 1AFFFFh
SA54	0	0	1	1	0	1	1	0	64/32	360000h to 36FFFFh	1B0000h to 1B7FFFh
SA55	0	0	1	1	0	1	1	1	64/32	370000h to 37FFFFh	1B8000h to 1BFFFFh
SA56	0	0	1	1	1	0	0	0	64/32	380000h to 38FFFFh	1C0000h to 1C7FFFh
SA57	0	0	1	1	1	0	0	1	64/32	390000h to 39FFFFh	1C8000h to 1CFFFFh
SA58	0	0	1	1	1	0	1	0	64/32	3A0000h to 3AFFFFh	1D0000h to 1D7FFFh
SA59	0	0	1	1	1	0	1	1	64/32	3B0000h to 3BFFFFh	1D8000h to 1DFFFFh
SA60	0	0	1	1	1	1	0	0	64/32	3C0000h to 3CFFFFh	1E0000h to 1E7FFFh
SA61	0	0	1	1	1	1	0	1	64/32	3D0000h to 3DFFFFh	1E8000h to 1EFFFFh
SA62	0	0	1	1	1	1	1	0	64/32	3E0000h to 3EFFFFh	1F0000h to 1F7FFFh

(Continued)

MBM29PL12LM₁₀

Sector	A ₂₂	A ₂₁	A ₂₀	A ₁₉	A ₁₈	A ₁₇	A ₁₆	A ₁₅	Sector size (Kbytes/ Kwords)	(×8) Address Range	(×16) Address Range
SA63	0	0	1	1	1	1	1	1	64/32	3F0000h to 3FFFFFFh	1F8000h to 1FFFFFFh
SA64	0	1	0	0	0	0	0	0	64/32	400000h to 40FFFFh	200000h to 207FFFh
SA65	0	1	0	0	0	0	0	1	64/32	410000h to 41FFFFh	208000h to 20FFFFFFh
SA66	0	1	0	0	0	0	1	0	64/32	420000h to 42FFFFh	210000h to 217FFFh
SA67	0	1	0	0	0	0	1	1	64/32	430000h to 43FFFFh	218000h to 21FFFFh
SA68	0	1	0	0	0	1	0	0	64/32	440000h to 44FFFFh	220000h to 227FFFh
SA69	0	1	0	0	0	1	0	1	64/32	450000h to 45FFFFh	228000h to 22FFFFFFh
SA70	0	1	0	0	0	1	1	0	64/32	460000h to 46FFFFh	230000h to 237FFFh
SA71	0	1	0	0	0	1	1	1	64/32	470000h to 47FFFFh	238000h to 23FFFFFFh
SA72	0	1	0	0	1	0	0	0	64/32	480000h to 48FFFFh	240000h to 247FFFh
SA73	0	1	0	0	1	0	0	1	64/32	490000h to 49FFFFh	248000h to 24FFFFFFh
SA74	0	1	0	0	1	0	1	0	64/32	4A0000h to 4AFFFFh	250000h to 257FFFh
SA75	0	1	0	0	1	0	1	1	64/32	4B0000h to 4BFFFFh	258000h to 25FFFFFFh
SA76	0	1	0	0	1	1	0	0	64/32	4C0000h to 4CFFFFh	260000h to 267FFFh
SA77	0	1	0	0	1	1	0	1	64/32	4D0000h to 4DFFFFh	268000h to 26FFFFFFh
SA78	0	1	0	0	1	1	1	0	64/32	4E0000h to 4EFFFFh	270000h to 277FFFh
SA79	0	1	0	0	1	1	1	1	64/32	4F0000h to 4FFFFFFh	278000h to 27FFFFFFh
SA80	0	1	0	1	0	0	0	0	64/32	500000h to 50FFFFh	280000h to 287FFFh
SA81	0	1	0	1	0	0	0	1	64/32	510000h to 51FFFFh	288000h to 28FFFFFFh
SA82	0	1	0	1	0	0	1	0	64/32	520000h to 52FFFFh	290000h to 297FFFh
SA83	0	1	0	1	0	0	1	1	64/32	530000h to 53FFFFh	298000h to 29FFFFFFh
SA84	0	1	0	1	0	1	0	0	64/32	540000h to 54FFFFh	2A0000h to 2A7FFFh
SA85	0	1	0	1	0	1	0	1	64/32	550000h to 55FFFFh	2A8000h to 2AFFFFFFh
SA86	0	1	0	1	0	1	1	0	64/32	560000h to 56FFFFh	2B0000h to 2B7FFFh
SA87	0	1	0	1	0	1	1	1	64/32	570000h to 57FFFFh	2B8000h to 2BFFFFFFh
SA88	0	1	0	1	1	0	0	0	64/32	580000h to 58FFFFh	2C0000h to 2C7FFFh
SA89	0	1	0	1	1	0	0	1	64/32	590000h to 59FFFFh	2C8000h to 2CFFFFFFh
SA90	0	1	0	1	1	0	1	0	64/32	5A0000h to 5AFFFFh	2D0000h to 2D7FFFh
SA91	0	1	0	1	1	0	1	1	64/32	5B0000h to 5BFFFFh	2D8000h to 2DFFFFFFh
SA92	0	1	0	1	1	1	0	0	64/32	5C0000h to 5CFFFFh	2E0000h to 2EE7FFFh
SA93	0	1	0	1	1	1	0	1	64/32	5D0000h to 5DFFFFh	2E8000h to 2EFFFFh
SA94	0	1	0	1	1	1	1	0	64/32	5E0000h to 5EFFFFh	2F0000h to 2F7FFFh

(Continued)

Sector	A ₂₂	A ₂₁	A ₂₀	A ₁₉	A ₁₈	A ₁₇	A ₁₆	A ₁₅	Sector size (Kbytes/ Kwords)	(×8) Address Range	(×16) Address Range
SA95	0	1	0	1	1	1	1	1	64/32	5F0000h to 5FFFFFFh	2F8000h to 2FFFFFFh
SA96	0	1	1	0	0	0	0	0	64/32	600000h to 60FFFFh	300000h to 307FFFh
SA97	0	1	1	0	0	0	0	1	64/32	610000h to 61FFFFh	308000h to 30FFFFh
SA98	0	1	1	0	0	0	1	0	64/32	620000h to 62FFFFh	310000h to 317FFFh
SA99	0	1	1	0	0	0	1	1	64/32	630000h to 63FFFFh	318000h to 31FFFFh
SA100	0	1	1	0	0	1	0	0	64/32	640000h to 64FFFFh	320000h to 327FFFh
SA101	0	1	1	0	0	1	0	1	64/32	650000h to 65FFFFh	328000h to 32FFFFh
SA102	0	1	1	0	0	1	1	0	64/32	660000h to 66FFFFh	330000h to 337FFFh
SA103	0	1	1	0	0	1	1	1	64/32	670000h to 67FFFFh	338000h to 33FFFFh
SA104	0	1	1	0	1	0	0	0	64/32	680000h to 68FFFFh	340000h to 347FFFh
SA105	0	1	1	0	1	0	0	1	64/32	690000h to 69FFFFh	348000h to 34FFFFh
SA106	0	1	1	0	1	0	1	0	64/32	6A0000h to 6AFFFFh	350000h to 357FFFh
SA107	0	1	1	0	1	0	1	1	64/32	6B0000h to 6BFFFFh	358000h to 35FFFFh
SA108	0	1	1	0	1	1	0	0	64/32	6C0000h to 6CFFFFh	360000h to 367FFFh
SA109	0	1	1	0	1	1	0	1	64/32	6D0000h to 6DFFFFh	368000h to 36FFFFh
SA110	0	1	1	0	1	1	1	0	64/32	6E0000h to 6EFFFFh	370000h to 377FFFh
SA111	0	1	1	0	1	1	1	1	64/32	6F0000h to 6FFFFFFh	378000h to 37FFFFh
SA112	0	1	1	1	0	0	0	0	64/32	700000h to 70FFFFh	380000h to 387FFFh
SA113	0	1	1	1	0	0	0	1	64/32	710000h to 71FFFFh	388000h to 38FFFFh
SA114	0	1	1	1	0	0	1	0	64/32	720000h to 72FFFFh	390000h to 397FFFh
SA115	0	1	1	1	0	0	1	1	64/32	730000h to 73FFFFh	398000h to 39FFFFh
SA116	0	1	1	1	0	1	0	0	64/32	740000h to 74FFFFh	3A0000h to 3A7FFFh
SA117	0	1	1	1	0	1	0	1	64/32	750000h to 75FFFFh	3A8000h to 3AFFFFh
SA118	0	1	1	1	0	1	1	0	64/32	760000h to 76FFFFh	3B0000h to 3B7FFFh
SA119	0	1	1	1	0	1	1	1	64/32	770000h to 77FFFFh	3B8000h to 3BFFFFh
SA120	0	1	1	1	1	0	0	0	64/32	780000h to 78FFFFh	3C0000h to 3C7FFFh
SA121	0	1	1	1	1	0	0	1	64/32	790000h to 79FFFFh	3C8000h to 3CFFFFh
SA122	0	1	1	1	1	0	1	0	64/32	7A0000h to 7AFFFFh	3D0000h to 3D7FFFh
SA123	0	1	1	1	1	0	1	1	64/32	7B0000h to 7BFFFFh	3D8000h to 3DFFFFh
SA124	0	1	1	1	1	1	0	0	64/32	7C0000h to 7CFFFFh	3E0000h to 3E7FFFh

(Continued)

MBM29PL12LM₁₀

Sector	A ₂₂	A ₂₁	A ₂₀	A ₁₉	A ₁₈	A ₁₇	A ₁₆	A ₁₅	Sector size (Kbytes/ Kwords)	(×8) Address Range	(×16) Address Range
SA125	0	1	1	1	1	1	0	1	64/32	7D0000h to 7DFFFFh	3E8000h to 3EFFFFh
SA126	0	1	1	1	1	1	1	0	64/32	7E0000h to 7EFFFFh	3F0000h to 3F7FFFh
SA127	0	1	1	1	1	1	1	1	64/32	7F0000h to 7FFFFFFh	3F8000h to 3FFFFFFh
SA128	1	0	0	0	0	0	0	0	64/32	800000h to 80FFFFh	400000h to 407FFFh
SA129	1	0	0	0	0	0	0	1	64/32	810000h to 81FFFFh	408000h to 40FFFFh
SA130	1	0	0	0	0	0	1	0	64/32	820000h to 82FFFFh	410000h to 417FFFh
SA131	1	0	0	0	0	0	1	1	64/32	830000h to 83FFFFh	418000h to 41FFFFh
SA132	1	0	0	0	0	1	0	0	64/32	840000h to 84FFFFh	420000h to 427FFFh
SA133	1	0	0	0	0	1	0	1	64/32	850000h to 85FFFFh	428000h to 42FFFFh
SA134	1	0	0	0	0	1	1	0	64/32	860000h to 86FFFFh	430000h to 437FFFh
SA135	1	0	0	0	0	1	1	1	64/32	870000h to 87FFFFh	438000h to 43FFFFh
SA136	1	0	0	0	1	0	0	0	64/32	880000h to 88FFFFh	440000h to 447FFFh
SA137	1	0	0	0	1	0	0	1	64/32	890000h to 89FFFFh	448000h to 44FFFFh
SA138	1	0	0	0	1	0	1	0	64/32	8A0000h to 8AFFFFh	450000h to 457FFFh
SA139	1	0	0	0	1	0	1	1	64/32	8B0000h to 8BFFFFh	458000h to 45FFFFh
SA140	1	0	0	0	1	1	0	0	64/32	8C0000h to 8CFFFFh	460000h to 467FFFh
SA141	1	0	0	0	1	1	0	1	64/32	8D0000h to 8DFFFFh	468000h to 46FFFFh
SA142	1	0	0	0	1	1	1	0	64/32	8E0000h to 8EFFFFh	470000h to 477FFFh
SA143	1	0	0	0	1	1	1	1	64/32	8F0000h to 8FFFFFFh	478000h to 47FFFFh
SA144	1	0	0	1	0	0	0	0	64/32	900000h to 90FFFFh	480000h to 487FFFh
SA145	1	0	0	1	0	0	0	1	64/32	910000h to 91FFFFh	488000h to 48FFFFh
SA146	1	0	0	1	0	0	1	0	64/32	920000h to 92FFFFh	490000h to 497FFFh
SA147	1	0	0	1	0	0	1	1	64/32	930000h to 93FFFFh	498000h to 49FFFFh
SA148	1	0	0	1	0	1	0	0	64/32	940000h to 94FFFFh	4A0000h to 4A7FFFh
SA149	1	0	0	1	0	1	0	1	64/32	950000h to 95FFFFh	4A8000h to 4AFFFFh
SA150	1	0	0	1	0	1	1	0	64/32	960000h to 96FFFFh	4B0000h to 4B7FFFh
SA151	1	0	0	1	0	1	1	1	64/32	970000h to 97FFFFh	4B8000h to 4BFFFFh
SA152	1	0	0	1	1	0	0	0	64/32	980000h to 98FFFFh	4C0000h to 4C7FFFh
SA153	1	0	0	1	1	0	0	1	64/32	990000h to 99FFFFh	4C8000h to 4CFFFFh
SA154	1	0	0	1	1	0	1	0	64/32	9A0000h to 9AFFFFh	4D0000h to 4D7FFFh
SA155	1	0	0	1	1	0	1	1	64/32	9B0000h to 9BFFFFh	4D8000h to 4DFFFFh

(Continued)

Sector	A ₂₂	A ₂₁	A ₂₀	A ₁₉	A ₁₈	A ₁₇	A ₁₆	A ₁₅	Sector size (Kbytes/ Kwords)	(×8) Address Range	(×16) Address Range
SA156	1	0	0	1	1	1	0	0	64/32	9C0000h to 9CFFFFh	4E0000h to 4E7FFFh
SA157	1	0	0	1	1	1	0	1	64/32	9D0000h to 9DFFFFh	4E8000h to 4EFFFFh
SA158	1	0	0	1	1	1	1	0	64/32	9E0000h to 9EFFFFh	4F0000h to 4F7FFFh
SA159	1	0	0	1	1	1	1	1	64/32	9F0000h to 9FFFFFFh	4F8000h to 4FFFFFFh
SA160	1	0	1	0	0	0	0	0	64/32	A00000h to A0FFFFh	500000h to 507FFFh
SA161	1	0	1	0	0	0	0	1	64/32	A10000h to A1FFFFh	508000h to 50FFFFh
SA162	1	0	1	0	0	0	1	0	64/32	A20000h to A2FFFFh	510000h to 517FFFh
SA163	1	0	1	0	0	0	1	1	64/32	A30000h to A3FFFFh	518000h to 51FFFFh
SA164	1	0	1	0	0	1	0	0	64/32	A40000h to A4FFFFh	520000h to 527FFFh
SA165	1	0	1	0	0	1	0	1	64/32	A50000h to A5FFFFh	528000h to 52FFFFh
SA166	1	0	1	0	0	1	1	0	64/32	A60000h to A6FFFFh	530000h to 537FFFh
SA167	1	0	1	0	0	1	1	1	64/32	A70000h to A7FFFFh	538000h to 53FFFFh
SA168	1	0	1	0	1	0	0	0	64/32	A80000h to A8FFFFh	540000h to 547FFFh
SA169	1	0	1	0	1	0	0	1	64/32	A90000h to A9FFFFh	548000h to 54FFFFh
SA170	1	0	1	0	1	0	1	0	64/32	AA0000h to AAFFFFh	550000h to 557FFFh
SA171	1	0	1	0	1	0	1	1	64/32	AB0000h to ABFFFFh	558000h to 55FFFFh
SA172	1	0	1	0	1	1	0	0	64/32	AC0000h to ACFFFFh	560000h to 567FFFh
SA173	1	0	1	0	1	1	0	1	64/32	AD0000h to ADFFFFh	568000h to 56FFFFh
SA174	1	0	1	0	1	1	1	0	64/32	AE0000h to AEFFFFh	570000h to 577FFFh
SA175	1	0	1	0	1	1	1	1	64/32	AF0000h to AFFFFFFh	578000h to 57FFFFh
SA176	1	0	1	1	0	0	0	0	64/32	B00000h to B0FFFFh	580000h to 587FFFh
SA177	1	0	1	1	0	0	0	1	64/32	B10000h to B1FFFFh	588000h to 58FFFFh
SA178	1	0	1	1	0	0	1	0	64/32	B20000h to B2FFFFh	590000h to 597FFFh
SA179	1	0	1	1	0	0	1	1	64/32	B30000h to B3FFFFh	598000h to 59FFFFh
SA180	1	0	1	1	0	1	0	0	64/32	B40000h to B4FFFFh	5A0000h to 5A7FFFh
SA181	1	0	1	1	0	1	0	1	64/32	B50000h to B5FFFFh	5A8000h to 5AFFFFh
SA182	1	0	1	1	0	1	1	0	64/32	B60000h to B6FFFFh	5B0000h to 5B7FFFh
SA183	1	0	1	1	0	1	1	1	64/32	B70000h to B7FFFFh	5B8000h to 5BFFFFh
SA184	1	0	1	1	1	0	0	0	64/32	B80000h to B8FFFFh	5C0000h to 5C7FFFh
SA185	1	0	1	1	1	0	0	1	64/32	B90000h to B9FFFFh	5C8000h to 5CFFFFh

(Continued)

MBM29PL12LM₁₀

Sector	A ₂₂	A ₂₁	A ₂₀	A ₁₉	A ₁₈	A ₁₇	A ₁₆	A ₁₅	Sector size (Kbytes/ Kwords)	(×8) Address Range	(×16) Address Range
SA186	1	0	1	1	1	0	1	0	64/32	BA0000h to BAFFFFh	5D0000h to 5D7FFFh
SA187	1	0	1	1	1	0	1	1	64/32	BB0000h to BBFFFFh	5D8000h to 5DFFFFh
SA188	1	0	1	1	1	1	0	0	64/32	BC0000h to BCFFFFh	5E0000h to 5E7FFFh
SA189	1	0	1	1	1	1	0	1	64/32	BD0000h to BDFFFFh	5E8000h to 5EFFFFh
SA190	1	0	1	1	1	1	1	0	64/32	BE0000h to BEFFFFh	5F0000h to 5F7FFFh
SA191	1	0	1	1	1	1	1	1	64/32	BF0000h to BFFFFFh	5F8000h to 5FFFFFFh
SA192	1	1	0	0	0	0	0	0	64/32	C00000h to C0FFFFh	600000h to 607FFFh
SA193	1	1	0	0	0	0	0	1	64/32	C10000h to C1FFFFh	608000h to 60FFFFh
SA194	1	1	0	0	0	0	1	0	64/32	C20000h to C2FFFFh	610000h to 617FFFh
SA195	1	1	0	0	0	0	1	1	64/32	C30000h to C3FFFFh	618000h to 61FFFFh
SA196	1	1	0	0	0	1	0	0	64/32	C40000h to C4FFFFh	620000h to 627FFFh
SA197	1	1	0	0	0	1	0	1	64/32	C50000h to C5FFFFh	628000h to 62FFFFh
SA198	1	1	0	0	0	1	1	0	64/32	C60000h to C6FFFFh	630000h to 637FFFh
SA199	1	1	0	0	0	1	1	1	64/32	C70000h to C7FFFFh	638000h to 63FFFFh
SA200	1	1	0	0	1	0	0	0	64/32	C80000h to C8FFFFh	640000h to 647FFFh
SA201	1	1	0	0	1	0	0	1	64/32	C90000h to C9FFFFh	648000h to 64FFFFh
SA202	1	1	0	0	1	0	1	0	64/32	CA0000h to CAFFFFh	650000h to 657FFFh
SA203	1	1	0	0	1	0	1	1	64/32	CB0000h to CBFFFFh	658000h to 65FFFFh
SA204	1	1	0	0	1	1	0	0	64/32	CC0000h to CCFFFFh	660000h to 667FFFh
SA205	1	1	0	0	1	1	0	1	64/32	CD0000h to CDFFFFh	668000h to 66FFFFh
SA206	1	1	0	0	1	1	1	0	64/32	CE0000h to CEFFFFh	670000h to 677FFFh
SA207	1	1	0	0	1	1	1	1	64/32	CF0000h to CFFFFFh	678000h to 67FFFFh
SA208	1	1	0	1	0	0	0	0	64/32	D00000h to D0FFFFh	680000h to 687FFFh
SA209	1	1	0	1	0	0	0	1	64/32	D10000h to D1FFFFh	688000h to 68FFFFh
SA210	1	1	0	1	0	0	1	0	64/32	D20000h to D2FFFFh	690000h to 697FFFh
SA211	1	1	0	1	0	0	1	1	64/32	D30000h to D3FFFFh	698000h to 69FFFFh
SA212	1	1	0	1	0	1	0	0	64/32	D40000h to D4FFFFh	6A0000h to 6A7FFFh
SA213	1	1	0	1	0	1	0	1	64/32	D50000h to D5FFFFh	6A8000h to 6AFFFFh
SA214	1	1	0	1	0	1	1	0	64/32	D60000h to D6FFFFh	6B0000h to 6B7FFFh
SA215	1	1	0	1	0	1	1	1	64/32	D70000h to D7FFFFh	6B8000h to 6BFFFFh

(Continued)

Sector	A ₂₂	A ₂₁	A ₂₀	A ₁₉	A ₁₈	A ₁₇	A ₁₆	A ₁₅	Sector size (Kbytes/ Kwords)	(×8) Address Range	(×16) Address Range
SA216	1	1	0	1	1	0	0	0	64/32	D8000h to D8FFFFh	6C0000h to 6C7FFFh
SA217	1	1	0	1	1	0	0	1	64/32	D90000h to D9FFFFh	6C8000h to 6CFFFFh
SA218	1	1	0	1	1	0	1	0	64/32	DA0000h to DAFFFFh	6D0000h to 6D7FFFh
SA219	1	1	0	1	1	0	1	1	64/32	DB0000h to DBFFFFh	6D8000h to 6DFFFFh
SA220	1	1	0	1	1	1	0	0	64/32	DC0000h to DCFFFFh	6E0000h to 6E7FFFh
SA221	1	1	0	1	1	1	0	1	64/32	DD0000h to DDFFFFh	6E8000h to 6EFFFFh
SA222	1	1	0	1	1	1	1	0	64/32	DE0000h to DEFFFFh	6F0000h to 6F7FFFh
SA223	1	1	0	1	1	1	1	1	64/32	DF0000h to DFFFFFh	6F8000h to 6FFFFFh
SA224	1	1	1	0	0	0	0	0	64/32	E00000h to E0FFFFh	700000h to 707FFFh
SA225	1	1	1	0	0	0	0	1	64/32	E10000h to E1FFFFh	708000h to 70FFFFh
SA226	1	1	1	0	0	0	1	0	64/32	E20000h to E2FFFFh	710000h to 717FFFh
SA227	1	1	1	0	0	0	1	1	64/32	E30000h to E3FFFFh	718000h to 71FFFFh
SA228	1	1	1	0	0	1	0	0	64/32	E40000h to E4FFFFh	720000h to 727FFFh
SA229	1	1	1	0	0	1	0	1	64/32	E50000h to E5FFFFh	728000h to 72FFFFh
SA230	1	1	1	0	0	1	1	0	64/32	E60000h to E6FFFFh	730000h to 737FFFh
SA231	1	1	1	0	0	1	1	1	64/32	E70000h to E7FFFFh	738000h to 73FFFFh
SA232	1	1	1	0	1	0	0	0	64/32	E80000h to E8FFFFh	740000h to 747FFFh
SA233	1	1	1	0	1	0	0	1	64/32	E90000h to E9FFFFh	748000h to 74FFFFh
SA234	1	1	1	0	1	0	1	0	64/32	EA0000h to EAFFFFh	750000h to 757FFFh
SA235	1	1	1	0	1	0	1	1	64/32	EB0000h to EBFFFFh	758000h to 75FFFFh
SA236	1	1	1	0	1	1	0	0	64/32	EC0000h to ECFFFFh	760000h to 767FFFh
SA237	1	1	1	0	1	1	0	1	64/32	ED0000h to EDFFFFh	768000h to 76FFFFh
SA238	1	1	1	0	1	1	1	0	64/32	EE0000h to EEFFFFh	770000h to 777FFFh
SA239	1	1	1	0	1	1	1	1	64/32	EF0000h to EFFFFFh	778000h to 77FFFFh
SA240	1	1	1	1	0	0	0	0	64/32	F00000h to F0FFFFh	780000h to 787FFFh
SA241	1	1	1	1	0	0	0	1	64/32	F10000h to F1FFFFh	788000h to 78FFFFh
SA242	1	1	1	1	0	0	1	0	64/32	F20000h to F2FFFFh	790000h to 797FFFh
SA243	1	1	1	1	0	0	1	1	64/32	F30000h to F3FFFFh	798000h to 79FFFFh
SA244	1	1	1	1	0	1	0	0	64/32	F40000h to F4FFFFh	7A0000h to 7A7FFFh
SA245	1	1	1	1	0	1	0	1	64/32	F50000h to F5FFFFh	7A8000h to 7AFFFFh

(Continued)

MBM29PL12LM₁₀

(Continued)

Sector	A ₂₂	A ₂₁	A ₂₀	A ₁₉	A ₁₈	A ₁₇	A ₁₆	A ₁₅	Sector size (Kbytes/ Kwords)	(×8) Address Range	(×16) Address Range
SA246	1	1	1	1	0	1	1	0	64/32	F60000h to F6FFFFh	7B0000h to 7B7FFFh
SA247	1	1	1	1	0	1	1	1	64/32	F70000h to F7FFFFh	7B8000h to 7BFFFFh
SA248	1	1	1	1	1	0	0	0	64/32	F80000h to F8FFFFh	7C0000h to 7C7FFFh
SA249	1	1	1	1	1	0	0	1	64/32	F90000h to F9FFFFh	7C8000h to 7CFFFFh
SA250	1	1	1	1	1	0	1	0	64/32	FA0000h to FAFFFFh	7D0000h to 7D7FFFh
SA251	1	1	1	1	1	0	1	1	64/32	FB0000h to FBFFFFh	7D8000h to 7DFFFFh
SA252	1	1	1	1	1	1	0	0	64/32	FC0000h to FCFFFFh	7E0000h to 7E7FFFh
SA253	1	1	1	1	1	1	0	1	64/32	FD0000h to FDFFFFh	7E8000h to 7EFFFFh
SA254	1	1	1	1	1	1	1	0	64/32	FE0000h to FEFFFFh	7F0000h to 7F7FFFh
SA255	1	1	1	1	1	1	1	1	64/32	FF0000h to FFFFFFFh	7F8000h to 7FFFFFFh

Note : The address range is A₂₂ to A₋₁ if in Byte mode ($\overline{\text{BYTE}} = V_{\text{IL}}$) .
 The address range is A₂₂ to A₀ if in Word mode ($\overline{\text{BYTE}} = V_{\text{IH}}$) .

Sector Group Address Table (MBM29PL12LM)

Sector Group	A ₂₂	A ₂₁	A ₂₀	A ₁₉	A ₁₈	A ₁₇	A ₁₆	A ₁₅	Sector group size (Kbytes/Kwords)	Sectors
SGA0	0	0	0	0	0	0	0	0	64/32	SA0
SGA1	0	0	0	0	0	0	0	1	64/32	SA1
SGA2	0	0	0	0	0	0	1	0	64/32	SA2
SGA3	0	0	0	0	0	0	1	1	64/32	SA3
SGA4	0	0	0	0	0	1	0	0	256/128	SA4 to SA7
SGA5	0	0	0	0	1	0	0	0	256/128	SA8 to SA11
SGA6	0	0	0	0	1	1	0	0	256/128	SA12 to SA15
SGA7	0	0	0	1	0	0	0	0	256/128	SA16 to SA19
SGA8	0	0	0	1	0	1	0	0	256/128	SA20 to SA23
SGA9	0	0	0	1	1	0	0	0	256/128	SA24 to SA27
SGA10	0	0	0	1	1	1	0	0	256/128	SA28 to SA31
SGA11	0	0	1	0	0	0	0	0	256/128	SA32 to SA35
SGA12	0	0	1	0	0	1	0	0	256/128	SA36 to SA39
SGA13	0	0	1	0	1	0	0	0	256/128	SA40 to SA43
SGA14	0	0	1	0	1	1	0	0	256/128	SA44 to SA47
SGA15	0	0	1	1	0	0	0	0	256/128	SA48 to SA51
SGA16	0	0	1	1	0	1	0	0	256/128	SA52 to SA55
SGA17	0	0	1	1	1	0	0	0	256/128	SA56 to SA59
SGA18	0	0	1	1	1	1	0	0	256/128	SA60 to SA63
SGA19	0	1	0	0	0	0	0	0	256/128	SA64 to SA67
SGA20	0	1	0	0	0	1	0	0	256/128	SA68 to SA71
SGA21	0	1	0	0	1	0	0	0	256/128	SA72 to SA75
SGA22	0	1	0	0	1	1	0	0	256/128	SA76 to SA79
SGA23	0	1	0	1	0	0	0	0	256/128	SA80 to SA83
SGA24	0	1	0	1	0	1	0	0	256/128	SA84 to SA87
SGA25	0	1	0	1	1	0	0	0	256/128	SA88 to SA91
SGA26	0	1	0	1	1	1	0	0	256/128	SA92 to SA95
SGA27	0	1	1	0	0	0	0	0	256/128	SA96 to SA99
SGA28	0	1	1	0	0	1	0	0	256/128	SA100 to SA103
SGA29	0	1	1	0	1	0	0	0	256/128	SA104 to SA107
SGA30	0	1	1	0	1	1	0	0	256/128	SA108 to SA111
SGA31	0	1	1	1	0	0	0	0	256/128	SA112 to SA115
SGA32	0	1	1	1	0	1	0	0	256/128	SA116 to SA119
SGA33	0	1	1	1	1	0	0	0	256/128	SA120 to SA123
SGA34	0	1	1	1	1	1	0	0	256/128	SA124 to SA127

(Continued)

MBM29PL12LM₁₀

(Continued)

Sector Group	A ₂₂	A ₂₁	A ₂₀	A ₁₉	A ₁₈	A ₁₇	A ₁₆	A ₁₅	Sector group size (Kbytes/Kwords)	Sectors
SGA35	1	0	0	0	0	0	0	0	256/128	SA128 to SA131
SGA36	1	0	0	0	0	1	0	0	256/128	SA132 to SA135
SGA37	1	0	0	0	1	0	0	0	256/128	SA136 to SA139
SGA38	1	0	0	0	1	1	0	0	256/128	SA140 to SA143
SGA39	1	0	0	1	0	0	0	0	256/128	SA144 to SA147
SGA40	1	0	0	1	0	1	0	0	256/128	SA148 to SA151
SGA41	1	0	0	1	1	0	0	0	256/128	SA152 to SA155
SGA42	1	0	0	1	1	1	0	0	256/128	SA156 to SA159
SGA43	1	0	1	0	0	0	0	0	256/128	SA160 to SA163
SGA44	1	0	1	0	0	1	0	0	256/128	SA164 to SA167
SGA45	1	0	1	0	1	0	0	0	256/128	SA168 to SA171
SGA46	1	0	1	0	1	1	0	0	256/128	SA172 to SA175
SGA47	1	0	1	1	0	0	0	0	256/128	SA176 to SA179
SGA48	1	0	1	1	0	1	0	0	256/128	SA180 to SA183
SGA49	1	0	1	1	1	0	0	0	256/128	SA184 to SA187
SGA50	1	0	1	1	1	1	0	0	256/128	SA188 to SA191
SGA51	1	1	0	0	0	0	0	0	256/128	SA192 to SA195
SGA52	1	1	0	0	0	1	0	0	256/128	SA196 to SA199
SGA53	1	1	0	0	1	0	0	0	256/128	SA200 to SA203
SGA54	1	1	0	0	1	1	0	0	256/128	SA204 to SA207
SGA55	1	1	0	1	0	0	0	0	256/128	SA208 to SA211
SGA56	1	1	0	1	0	1	0	0	256/128	SA212 to SA215
SGA57	1	1	0	1	1	0	0	0	256/128	SA216 to SA219
SGA58	1	1	0	1	1	1	0	0	256/128	SA220 to SA223
SGA59	1	1	1	0	0	0	0	0	256/128	SA224 to SA227
SGA60	1	1	1	0	0	1	0	0	256/128	SA228 to SA231
SGA61	1	1	1	0	1	0	0	0	256/128	SA232 to SA235
SGA62	1	1	1	0	1	1	0	0	256/128	SA236 to SA239
SGA63	1	1	1	1	0	0	0	0	256/128	SA240 to SA243
SGA64	1	1	1	1	0	1	0	0	256/128	SA244 to SA247
SGA65	1	1	1	1	1	0	0	0	256/128	SA248 to SA251
SGA66	1	1	1	1	1	1	0	0	64/32	SA252
SGA67	1	1	1	1	1	1	0	1	64/32	SA253
SGA68	1	1	1	1	1	1	1	0	64/32	SA254
SGA69	1	1	1	1	1	1	1	1	64/32	SA255

Common Flash Memory Interface Code

A ₀ to A ₆	DQ ₀ to DQ ₁₅	Description
10h 11h 12h	0051h 0052h 0059h	Query-unique ASCII string "QRY"
13h 14h	0002h 0000h	Primary OEM Command Set (02h = Fujitsu standard)
15h 16h	0040h 0000h	Address for Primary Extended Table
17h 18h	0000h 0000h	Alternate OEM Command Set (00h = not applicable)
19h 1Ah	0000h 0000h	Address for Alternate OEM Extended Table (00h = not applicable)
1Bh	0027h	V _{CC} Min (write/erase) DQ ₇ to DQ ₄ : 1V/bit, DQ ₃ to DQ ₀ : 100 mV/bit
1Ch	0036h	V _{CC} Max (write/erase) DQ ₇ to DQ ₄ : 1V/bit, DQ ₃ to DQ ₀ : 100 mV/bit
1Dh	0000h	V _{PP} Min voltage (00h = no V _{pp} pin)
1Eh	0000h	V _{PP} Max voltage (00h =no V _{pp} pin)
1Fh	0007h	Typical timeout per single write 2 ^N μs
20h	0007h	Typical timeout for Min size buffer write 2 ^N μs
21h	000Ah	Typical timeout per individual sector erase 2 ^N ms
22h	0000h	Typical timeout for full chip erase 2 ^N ms
23h	0001h	Max timeout for write 2 ^N times typical
24h	0005h	Max timeout for buffer write 2 ^N times typical
25h	0004h	Max timeout per individual sector erase 2 ^N times typical
26h	0000h	Max timeout for full chip erase 2 ^N times typical
27h	0018h	Device Size = 2 ^N byte
28h 29h	0002h 0000h	Flash Device Interface description 02h : × 8/ × 16
2Ah 2Bh	0005h 0000h	Max number of byte in multi-byte write = 2 ^N
2Ch	0002h	Number of Erase Block Regions within device (02h = Boot)
2Dh 2Eh 2Fh 30h	007Fh 0000h 0020h 0000h	Erase Block Region 1 Information
31h 32h 33h 34h	003Eh 0000h 0000h 0001h	Erase Block Region 2 Information

(Continued)

MBM29PL12LM₁₀

(Continued)

A ₀ to A ₆	DQ ₀ to DQ ₁₅	Description
35h 36h 37h 38h	0000h 0000h 0000h 0000h	Erase Block Region 3 Information
39h 3Ah 3Bh 3Ch	0000h 0000h 0000h 0000h	Erase Block Region 4 Information
40h 41h 42h	0050h 0052h 0049h	Query-unique ASCII string "PRI"
43h	0031h	Major version number, ASCII
44h	0033h	Minor version number, ASCII
45h	0008h	Address Sensitive Unlock Required
46h	0002h	Erase Suspend (02h = To Read & Write)
47h	0001h	Number of sectors in per group
48h	0001h	Sector Temporary Unprotection (01h = Supported)
49h	0004h	Sector Group Protection Algorithm
4Ah	0000h	Dual Operation (00h = Not Supported)
4Bh	0000h	Burst Mode Type (00h = Not Supported)
4Ch	0001h	Page Mode Type (01h = 4-Word Page Supported)
4Dh	00B5h	V _{ACC} (Acceleration) Supply Minimum DQ ₇ to DQ ₄ : 1V/bit, DQ ₃ to DQ ₀ : 100mV/bit
4Eh	00C5h	V _{ACC} (Acceleration) Supply Maximum DQ ₇ to DQ ₄ : 1V/bit, DQ ₃ to DQ ₀ : 100mV/bit
4Fh	00XXh	CFI Write Protect (04h = Uniform Sectors Bottom Write Protection)
50h	01h	Program Suspend (01h = Supported)

■ FUNCTIONAL DESCRIPTION

Standby Mode

There are two ways to implement the standby mode on the device, one using both the \overline{CE} and \overline{RESET} pins, and the other via the \overline{RESET} pin only.

When using both pins, CMOS standby mode is achieved with \overline{CE} and \overline{RESET} input held at $V_{CC} \pm 0.3$ V. Under this condition the current consumed is less than 5 μ A Max. During Embedded Algorithm operation, V_{CC} active current (I_{CC2}) is required even when $\overline{CE} = "H"$. The device can be read with standard access time (t_{CE}) from either of these standby modes.

When using the \overline{RESET} pin only, CMOS standby mode is achieved with \overline{RESET} input held at $V_{SS} \pm 0.3$ V ($\overline{CE} = "H"$ or "L"). Under this condition the current consumed is less than 5 μ A Max. Once the \overline{RESET} pin is set high, the device requires t_{RH} as a wake-up time for output to be valid for read access.

During standby mode, the output is in the high impedance state, regardless of \overline{OE} input.

Automatic Sleep Mode

Automatic sleep mode works to restrain power consumption during read-out of device data. It can be useful in applications such as handy terminal, which requires low power consumption.

To activate this mode, the device automatically switch themselves to low power mode when the device addresses remain stable after 30 ns from data valid. It is not necessary to control \overline{CE} , \overline{WE} , and \overline{OE} in this mode. The current consumed is typically 1 μ A (CMOS Level).

Since the data are latched during this mode, the data are continuously read out. When the addresses are changed, the mode is automatically canceled and the device read-out the data for changed addresses.

Autoselect

The Autoselect mode allows reading out of a binary code and identifies its manufacturer and type. It is intended for use by programming equipment for the purpose of automatically matching the device to be programmed with its corresponding programming algorithm.

To activate this mode, the programming equipment must force V_{ID} on address pin A_9 . Three identifier bytes may then be sequenced from the devices outputs by toggling A_0 . All addresses can be either High or Low except A_6 , A_3 , A_2 , A_1 and A_0 . See "MBM29PL12LM User Bus Operations (Word Mode : $\overline{BYTE} = V_{IH}$)" and "MBM29PL12LM User Bus Operations (Byte Mode : $\overline{BYTE} = V_{IL}$)" in ■DEVICE BUS OPERATION.

The manufacturer and device codes may also be read via the command register, for instances when the device is erased or programmed in a system without access to high voltage on the A_9 pin. The command sequence is illustrated in "MBM29PL12LM Standard Command Definitions" in ■DEVICE BUS OPERATION. Refer to Autoselect Command section.

In Word mode, a read cycle from address 00h returns the manufacturer's code (Fujitsu = 04h) . A read cycle at address 01h outputs device code. When 227Eh is output, it indicates that two additional codes, called Extended Device Codes will be required. Therefore the system may continue reading out these Extended Device Codes at addresses of 0Eh and 0Fh. Notice that the above applies to Word mode. The addresses and codes differ from those of Byte mode. Refer to "Sector Group Protection Verify Autoselect Codes" in ■DEVICE BUS OPERATION.

Read Mode

The device has two control functions required to obtain data at the outputs. \overline{CE} is the power control and used for a device selection. \overline{OE} is the output control and used to gate data to the output pins.

Address access time (t_{ACC}) is equal to the delay from stable addresses to valid output data. The chip enable access time (t_{CE}) is the delay from stable addresses and stable \overline{CE} to valid data at the output pins. The output enable access time (t_{OE}) is the delay from the falling edge of \overline{OE} to valid data at the output pins. (Assuming the addresses have been stable for at least $t_{ACC}-t_{OE}$ time.) When reading out a data without changing addresses after power-up, to input hardware reset or to change \overline{CE} pin from "H" or "L".

Page Mode Read

The device is capable of fast read access for random locations within limited address location called page. The page size of the device is 8 bytes / 4 words, within the appropriate page being selected by the higher address bits A_{22} to A_2 and the address bits A_1 to A_0 in Word mode (A_1 to A_{-1} in Byte mode) determining the specific word within that page. This is an asynchronous operation with the microprocessor supplying the specific word location.

The initial page access is equal to the random access (t_{ACC}) and subsequent Page read access (as long as the locations specified by the microprocessor fall within that Page) is equivalent to the page address access time (t_{PACC}). Here again, \overline{CE} selects the device and \overline{OE} is the output control and should be used to gate data to the output pins if the device is selected. Fast Page mode, accesses are obtained by keeping A_{20} to A_2 constant and changing A_1 and A_0 in Word mode (A_1 to A_{-1} in Byte mode) to select the specific word within that Page.

Refer to “Read Operation Timing Diagram” in ■TIMING DIAGRAM.

Output Disable

With the \overline{OE} input at logic high level (V_{IH}), output from the devices are disabled. This may cause the output pins to be in a high impedance state.

Write

Device erasure and programming are accomplished via the command register. The contents of the register serve as inputs to the internal state machine. The state machine outputs dictate the device function.

The command register itself does not occupy any addressable memory location. The register is a latch used to store the commands, along with the address and data information needed to execute the command. The command register is written by bringing \overline{WE} to V_{IL} , while \overline{CE} is at V_{IL} and \overline{OE} is at V_{IH} . Addresses are latched on the falling edge of \overline{WE} or \overline{CE} , whichever starts later; while data is latched on the rising edge of \overline{WE} or \overline{CE} , whichever starts first. Standard microprocessor write timings are used.

Refer to AC Write Characteristics and the Erase/Programming Waveforms for specific timing parameters.

Sector Group Protection

The device features hardware sector group protection. This feature will disable both program and erase operations in any combination of 70 sector groups of memory. See “Sector Group Address Table (MBM29PL12LM)” in ■DEVICE BUS OPERATION. The user’s side can use the sector group protection using programming equipment. The device is shipped with all sector groups that are unprotected.

To activate it, the programming equipment must force V_{ID} on address pin A_9 and control pin \overline{OE} , $\overline{CE} = V_{IL}$ and $(A_6, A_3, A_2, A_1, A_0) = (0, 0, 0, 1, 0)$. The sector group addresses ($A_{22}, A_{21}, A_{20}, A_{19}, A_{18}, A_{17}, A_{16}$, and A_{15}) should be set to the sector to be protected. “Sector Group Address Table (MBM29PL12LM)” in ■DEVICE BUS OPERATION defines the sector address for each of the 70 individual sectors, and “Sector Group Address Table (MBM29PL12LM)” in ■DEVICE BUS OPERATION defines the sector group address for each of the twenty-four (24) individual group sectors. Programming of the protection circuitry begins on the falling edge of the \overline{WE} pulse and is terminated with the rising edge of the same. Sector group addresses must be held constant during the \overline{WE} pulse. See “Sector Group Protection Timing Diagram” in ■TIMING DIAGRAM and “Sector Group Protection Algorithm” in ■FLOW CHART for sector group protection timing diagram and algorithm.

To verify programming of the protection circuitry, the programming equipment must force V_{ID} on address pin A_9 with \overline{CE} and \overline{OE} at V_{IL} and \overline{WE} at V_{IH} . Scanning the sector group addresses ($A_{22}, A_{21}, A_{20}, A_{19}, A_{18}, A_{17}, A_{16}$, and A_{15}) while $(A_6, A_3, A_2, A_1, A_0) = (0, 0, 0, 1, 0)$ will produce a logical “1” code at device output DQ_0 for a protected sector. Otherwise the device will produce “0” for unprotected sectors. In this mode, the lower order addresses, except for A_0, A_1, A_2, A_3 , and A_6 can be either High or Low. Address locations with $A_1 = V_{IL}$ are reserved for Autoselect manufacturer and device codes. A_{-1} requires applying to V_{IL} on Byte mode.

It is also possible to determine if a sector group is protected in the system by writing an Autoselect command. Performing a read operation at the address location $XX02h$, where the higher order addresses ($A_{22}, A_{21}, A_{20}, A_{19}, A_{18}, A_{17}, A_{16}$, and A_{15}) are the desired sector group address will produce a logical “1” at DQ_0 for a protected sector group. See “MBM29PL12LM User Bus Operations (Word Mode : $\overline{BYTE} = V_{IH}$)” and “Sector Group Protection Verify Autoselect Codes” in ■DEVICE BUS OPERATION for Autoselect codes.

Temporary Sector Group Unprotection

This feature allows temporary unprotection of previously protected sector groups of the devices in order to change data. The Sector Group Unprotection mode is activated by setting the $\overline{\text{RESET}}$ pin to high voltage (V_{ID}). During this mode, formerly protected sector groups can be programmed or erased by selecting the sector group addresses. Once the V_{ID} is taken away from the $\overline{\text{RESET}}$ pin, all the previously protected sector groups will be protected again. Refer to “Temporary Sector Group Unprotection Timing Diagram” in ■TIMING DIAGRAM and “Temporary Sector Group Unprotection Algorithm” in ■FLOW CHART.

Hardware Reset

The devices may be reset by driving the $\overline{\text{RESET}}$ pin to V_{IL} from V_{IH} . The $\overline{\text{RESET}}$ pin has a pulse requirement and has to be kept low (V_{IL}) for at least “ t_{RP} ” in order to properly reset the internal state machine. Any operation in the process of being executed will be terminated and the internal state machine will be reset to the read mode “ t_{READY} ” after the $\overline{\text{RESET}}$ pin is driven low. When the $\overline{\text{RESET}}$ pin is low, the devices will be in the standby mode for the duration of the pulse and all the data output pins will be tri-stated. If a hardware reset occurs during a program or erase operation, the data at that particular location will be corrupted.

Furthermore, once the $\overline{\text{RESET}}$ pin goes high, the devices require an additional “ t_{RH} ” before it will allow read access.

Write Protect ($\overline{\text{WP}}$)

The Write Protection function provides a hardware method of protecting certain first 64K bytes / 32K words sector without using V_{ID} . This function is one of two provided by the $\overline{\text{WP/ACC}}$ pin.

If the system asserts V_{IL} on the $\overline{\text{WP/ACC}}$ pin, the device disables program and erase functions in the first 64K bytes / 32K words sector independently of whether this sector was protected or unprotected using the method described in “Sector Group Protection” above.

If the system asserts V_{IH} on the $\overline{\text{WP/ACC}}$ pin, the device reverts of whether the first 64K bytes / 32K words sectors were last set to be protected to the unprotected status. Sector protection or unprotection for this sector depends on whether this was last protected or unprotected using the method described in “Sector protection/unprotection”.

Accelerated Program Operation

The device offers accelerated program operation which enables programming in high speed. If the system asserts V_{ACC} to the $\overline{\text{WP/ACC}}$ pin, the device automatically enters the acceleration mode and the time required for program operation will reduce to about 85%. This function is primarily intended to allow high speed programming, so caution is needed as the sector group becomes temporarily unprotected.

The system would use a fast program command sequence when programming during acceleration mode. Set command to fast mode and reset command from fast mode are not necessary. When the device enters the acceleration mode, the device is automatically set to fast mode. Therefore, the present command and sequence could be used for programming and detection of completion during acceleration mode.

Removing V_{ACC} from the $\overline{\text{WP/ACC}}$ pin returns the device to normal operation. Do not remove V_{ACC} from the $\overline{\text{WP/ACC}}$ pin while programming. See “Accelerated Program Timing Diagram” in ■TIMING DIAGRAM.

V_{CCQ}

V_{CCQ} determines the MBM29PL12LM voltage output. V_{CCQ} facilitates signal exchange within devices that operate in different voltage.

■ COMMAND DEFINITIONS

Device operations are selected by writing specific address and data sequences into the command register. “MBM29PL12LM Standard Command Definitions” in ■DEVICE BUS OPERATION shows the valid register command sequences. Note that the Erase Suspend (B0h) and Erase Resume (30h) commands are valid only while the Sector Erase operation is in progress. Also the Program Suspend (B0h) and Program Resume (30h) commands are valid only while the program operation is in progress. Moreover reset commands are functionally equivalent. Please note that commands must be asserted to DQ₇ to DQ₀ and DQ₁₅ to DQ₈ bits are ignored.

Reset Command

In order to return from Autoselect mode or Exceeded Timing Limits (DQ₅ = 1) to Read mode, the Reset operation is initiated by writing the reset command sequence into the command register. The devices remain enabled for reads until the command register contents are altered.

The devices will automatically be in the reset state after power-up. In this case, a command sequence is not required in order to read data.

Autoselect Command

Flash memories are intended for use in applications where the local CPU alters memory contents. Therefore, manufacture and device codes must be accessible while the devices reside in the target system. PROM programmers typically access the signature codes by raising A₉ to a high voltage. However applying high voltage onto the address lines is not generally desired system design practice.

The device contains an Autoselect command operation to supplement traditional PROM programming methodology. The operation is initiated by writing the Autoselect command sequence into the command register.

The Autoselect command sequence is initiated first by writing two unlock cycles. This is followed by a third write cycle that contains the address and the Autoselect command. Then the manufacture and device codes can be read from the address, and an actual data of memory cell can be read from the another address.

Following the command write, a read cycle from address 00h returns the manufactures's code (Fujitsu = 04h). A read cycle at address 01h outputs device code. When 227Eh is output, it indicates that two additional codes, called Extended Device Codes will be required. Therefore the system may continue reading out these Extended Device Codes at address of 0Eh as well as at 0Fh. Notice that above applies to Word mode. The addresses and codes differ from those of Byte mode. Refer to “Sector Group Protection Verify Autoselect Codes” in ■DEVICE BUS OPERATION.

To terminate the operation, it is necessary to write the reset command into the register. To execute the Autoselect command during the operation, reset command must be written before the Autoselect command.

Programming

The devices are programmed on a word-by-word basis. Programming is a 4 bus cycle operation. There are two “unlock” write cycles. These are followed by the program set-up command and data write cycles. Addresses are latched on the falling edge of \overline{CE} or \overline{WE} , whichever happens later and the data is latched on the rising edge of \overline{CE} or \overline{WE} , whichever happens first. The rising edge of the last \overline{CE} or \overline{WE} (whichever happens first) starts programming. Upon executing the Embedded Program Algorithm command sequence, the system is not required to provide further controls. The device will automatically provide adequate internally generated program pulses and verify the programmed cell margin.

The system can determine the status of the program operation by using DQ₇ ($\overline{\text{Data Polling}}$), DQ₆ (Toggle Bit) or RY/BY. The Data Polling and Toggle Bit are automatically performed at the memory location being programmed.

The programming operation is completed when the data on DQ₇ is equivalent to data written to this bit at which the devices return to the read mode and program addresses are no longer latched. Therefore, the devices require that a valid address to the devices be supplied by the system at this particular instance. Hence $\overline{\text{Data Polling}}$ requires the same address which is being programmed.

If hardware reset occurs during the programming operation, the data being written is not guaranteed.

Programming is allowed in any address sequence and across sector boundaries. Beware that a data “0” cannot be programmed back to a “1”. Attempting to do so may result in either failure condition or an apparent success according to the data polling algorithm. But a read from reset command will show that the data is still “0”. Only erase operations can convert “0”s to “1”s.

Note that attempting to program a “1” over a “0” will result in programming failure. This precaution is the same with Fujitsu standard NOR devices. “Embedded Program™ Algorithm” in ■FLOW CHART illustrates the Embedded Program™ Algorithm using typical command strings and bus operations.

Program Suspend/Resume

The Program Suspend command allows the system to interrupt a program operation so that data can be read from any address. Writing the Program Suspend command (B0h) during Embedded Program operation immediately suspends the programming. Refer to "Erase Suspend/Resume" for the detail.

When the Program Suspend command is written during a programming process, the chip halts the program operation within 1 μ s and suspend the status bits. After the program operation has been suspended, the system can read data from any address. Normal read timing and command definitions apply. The data at program-suspended address is not valid.

After the Program Resume command (30h) is written, the chip reverts to programming. The system can determine the status of the program operation using the DQ7 or DQ6 status bits, just as in the standard program operation. See "Write Operation Status" for more information.

When issuing program suspend command in 4 μ s after issuing program command, determine the status of program operation by reading status bit at more 4 μ s after issuing program resume command.

The system also writes the Autoselect command sequence in the Program Suspend mode. The device allows reading Autoselect codes at the addresses within programming sectors, since the codes are not stored in the memory. When the device exits the Autoselect mode, the device reverts to the Program Suspend mode, and is ready for another valid operation. See "Autoselect Command Sequence" for more information.

The system must write the Program Resume command to exit from the Program Suspend mode and continue the programming operation. Further writes of the Resume command are ignored. Another Program Suspend command can be written after the chip resumes programming.

Write Buffer Programming Operations

Write Buffer Programming allows the system write to series of 16 words in one programming operation. This results in faster effective word programming time than the standard programming algorithms. The Write Buffer Programming command sequence is initialized by first writing two unlock cycles. This is followed by a third write cycle selecting the Sector Address in which programming will occur. In fourth cycle contains both Sector Address and unique code for data bus width will be loaded into the page buffer at the Sector Address in which programming will occur.

The system then writes the starting address/data combination. This “starting address” must be the same Sector Address used in third and fourth cycles and its lower addresses of A₃ to A₀ should be 0h. All subsequent address must be incremented by 000Fh. Addresses are latched on the falling edge of CE or WE, whichever happens later and the data is latched on the rising edge of CE or WE, whichever happens first. The rising edge of the last CE or WE (whichever happens first) starts programming. Upon executing the Write Buffer Programming Operations command sequence, the system is not required to provide further controls. The device will automatically provide adequate internally generated program pulses and verify the programmed cell margin.

DQ₇(Data Polling), DQ₆(Toggle Bit), DQ₅(Exceeded Timing Limits), DQ₁(Write-to-Buffer Abort) should be monitored to determine the device status during Write Buffer Programming. In addition to these functions, it is also possible to indicate to the host system that Write Buffer Programming Operations are either in progress or have been completed by RY/BY. See “Hardware Sequence Flags”.

The $\overline{\text{Data}}$ polling techniques described in “ $\overline{\text{Data}}$ Polling Algorithm” in ■FLOW CHART should be used while monitoring the last address location loaded into the write buffer. In addition, it is not necessary to specify an address in Toggle Bit techniques described in “Toggle Bit Algorithm” in ■FLOW CHART. The automatic pro-

programming operation is completed when the data on DQ₇ is equivalent to the data written to this bit at which time the device returns to the read mode (See "Hardware Sequence Flags").

The write-buffer programming operation can be suspended/resumed using the standard program suspend/resume commands.

Once the write buffer programming is set, the system must then write the "Program Buffer to Flash" command at the Sector Address. Any other address/data combination will abort the Write Buffer Programming operation and the device will continue busy state.

The Write Buffer Programming Sequence can be ABORTED by doing the following :

- Different Sector Address is asserted.
- Write data other than the "Program Buffer to Flash" command after the specified number of "data load" cycles.

A "Write-to-Buffer-Abort Reset" command sequence must be written to the device to return to read mode. (See "MBM29PL12LM Standard Command Definitions" in ■DEVICE BUS OPERATION for details on this command sequence.)

Chip Erase

Chip erase is a 6 bus cycle operation. It begins two "unlock" write cycles followed by writing the "set-up" command, and two "unlock" write cycles followed by the chip erase command which invokes the Embedded Erase algorithm.

The device does not require the user to program the device prior to erase. Upon executing the Embedded Erase Algorithm the devices automatically programs and verifies the entire memory for an all 0 data pattern prior to electrical erase (Preprogram function). The system is not required to provide any controls or timings during these operations.

The system can determine the erase operation status by using DQ₇ ($\overline{\text{Data}}$ Polling), DQ₆ (Toggle Bit) and DQ₂ (Toggle Bit II) or RY/ $\overline{\text{BY}}$ output signal. The chip erase begins on the rising edge of the last $\overline{\text{CE}}$ or $\overline{\text{WE}}$, whichever happens first from last command sequence and completes when the data on DQ₇ is "1" at which time the device returns to read mode.

Sector Erase

Sector erase is a 6 bus cycle operation. There are two "unlock" write cycles. These are followed by writing the "set-up" command. Two more "unlock" write cycles are then followed by the Sector Erase command.

Multiple sectors may be erased concurrently by writing the same six bus cycle operations. This sequence is followed by writes of the Sector Erase command to addresses in other sectors desired to be concurrently erased. The time between writes must be less than Erase Time-out time(t_{row}). Otherwise that command will not be accepted and erasure will not start. It is recommended that processor interrupts be disabled during this time to guarantee this condition. The interrupts can reoccur after the last Sector Erase command is written. A time-out of " t_{row} " from the rising edge of last $\overline{\text{CE}}$ or $\overline{\text{WE}}$, whichever happens first, will initiate the execution of the Sector Erase command(s). If another falling edge of $\overline{\text{CE}}$ or $\overline{\text{WE}}$, whichever happens first occurs within the " t_{row} " time-out window the timer is reset (monitor DQ₃ to determine if the sector erase timer window is still open, see section DQ₃, Sector Erase Timer). Resetting the devices once execution has begun will corrupt the data in the sector. In that case, restart the erase on those sectors and allow them to complete (refer to the Write Operation Status). Loading the sector erase buffer may be done in any sequence and with any number of sectors (0 to 255).

Sector erase does not require the user to program the devices prior to erase. The devices automatically program all memory locations in the sector(s) to be erased prior to electrical erase using the Embedded Erase Algorithm. When erasing a sector, the remaining unselected sectors remain unaffected. The system is not required to provide any controls or timings during these operations.

The system can determine the status of the erase operation by using DQ₇ ($\overline{\text{Data}}$ Polling), DQ₆ (Toggle Bit) or RY/ $\overline{\text{BY}}$.

The sector erase begins after the " t_{row} " time-out from the rising edge of $\overline{\text{CE}}$ or $\overline{\text{WE}}$ whichever happens first for the last sector erase command pulse and completes when the data on DQ₇ is "1" (see Write Operation Status section), at which the devices return to the read mode. $\overline{\text{Data}}$ polling and Toggle Bit must be performed at an address within any of the sectors being erased.

Erase Suspend/Resume

The Erase Suspend command allows the user to interrupt Sector Erase operation and then perform read to a sector not being erased. This command is applicable **ONLY** during the Sector Erase operation within the time-out period for sector erase. Writing the Erase Suspend command (B0h) during the Sector Erase time-out results in immediate termination of the time-out period and suspension of the erase operation.

Writing the "Erase Resume" command resumes the erase operation.

When the "Erase Suspend" command is written during the Sector Erase operation, the device takes maximum of "t_{SPD}" to suspend the erase operation. When the devices enter the erase-suspended mode, the RY/ $\overline{\text{BY}}$ output pin will be at High-Z and the DQ₇ bit will be at logic "1" and DQ₆ will stop toggling. The user must use the address of the erasing sector for reading DQ₆ and DQ₇ to determine if the erase operation has been suspended. Further writes of the Erase Suspend command are ignored.

When the erase operation is suspended, the devices default to the erase-suspend-read mode. Reading data in this mode is the same as reading from the standard read mode, except that the data must be read from sectors that have not been erase-suspended. Reading successively from the erase-suspended sector while the device is in the erase-suspend-read mode will cause DQ₂ to toggle. See the section on DQ₂.

To resume the operation of Sector Erase, the Resume command (30h) should be written. Any further writes of the Resume command at this point will be ignored. Another Erase Suspend command can be written after the chip has resumed erasing.

Do not issue program command after entering erase-suspend-read mode.

Fast Mode Set/Reset

The device has Fast Mode function. It dispenses with the initial two unlock cycles required in the standard program command sequence by writing Fast Mode command into the command register. In this mode, the required bus cycle for programming consists of two cycles instead of 4 bus cycles in standard program command. The read operation is also executed after exiting this mode. During the Fast mode, do not write any command other than the Fast program/Fast mode reset command. To exit from this mode, write Fast Mode Reset command into the command register. (Refer to the "Embedded Program™ Algorithm for Fast Mode" in ■FLOW CHART.) The V_{CC} active current is required even $\overline{\text{CE}} = V_{\text{IH}}$ during Fast Mode.

Fast Programming

During Fast Mode, the programming can be executed with 2 bus cycles operation. The Embedded Program Algorithm is executed by writing program set-up command (A0h) and data write cycles (PA/PD). See "Embedded Program™ Algorithm for Fast Mode" in ■FLOW CHART.

Extended Sector Group Protection

In addition to normal sector group protection, the device has Extended Sector Group Protection as extended function. This function enables protection of the sector group by forcing V_{ID} on \overline{RESET} pin and writes a command sequence. Unlike conventional procedures, it is not necessary to force V_{ID} and control timing for control pins. The only \overline{RESET} pin requires V_{ID} for sector group protection in this mode. The extended sector group protection requires V_{ID} on \overline{RESET} pin. With this condition, the operation is initiated by writing the set-up command (60h) into the command register. Then the sector group addresses pins ($A_{22}, A_{21}, A_{20}, A_{19}, A_{18}, A_{17}, A_{16}$ and A_{15}) and (A_6, A_3, A_2, A_1, A_0) = (0, 0, 0, 1, 0) should be set to the sector group to be protected (set V_{IL} for the other addresses pins is recommended), and write extended sector group protection command (60h). A sector group is typically protected in 250 μ s. To verify programming of the protection circuitry, the sector group addresses pins (A_6, A_3, A_2, A_1, A_0) = (0, 0, 0, 1, 0) should be set and write a command (40h). Following the command write, a logical "1" at device output DQ_0 will produce for protected sector in the read operation. If the output data is logical "0", write the extended sector group protection command (60h) again. To terminate the operation, set \overline{RESET} pin to V_{IH} . (Refer to the "Extended Sector Group Protection Timing Diagram" in ■TIMING DIAGRAM and "Extended Sector Group Protection Algorithm" in ■FLOW CHART.)

Query Command (CFI : Common Flash Memory Interface)

The CFI (Common Flash Memory Interface) specification outlines device and host system software interrogation handshake which allows specific vendor-specified software algorithms to be used for entire families of devices. This allows device-independent, JEDEC ID-independent, and forward-and backward-compatible software support for the specified flash device families. Refer to CFI specification in detail.

The operation is initiated by writing the query command (98h) into the command register. Following the command write, a read cycle from specific address retrieves device information. Please note that output data of upper byte (DQ_{15} to DQ_8) is "0". Refer to the CFI code table. To terminate operation, it is necessary to write the Reset command sequence into the register. (See "Common Flash Memory Interface Code" in ■DEVICE BUS OPERATION.)

HiddenROM Mode

(1) HiddenROM Region

The HiddenROM (HiddenROM) feature provides a Flash memory region that the system may access through a new command sequence. This is primarily intended for customers who wish to use an Electronic Serial Number (ESN) in the device with the ESN protected against modification. Once the HiddenROM region is protected, any further modification of that region is impossible. This ensures the security of the ESN once the product is shipped to the field.

The HiddenROM region is 256 bytes / 128 words in length. After the system writes the HiddenROM Entry command sequence, it may read the HiddenROM region by using device addresses A_6 to A_0 (A_{22} to A_{15} are all "0"). That is, the device sends only program command that would normally be sent to the address to the HiddenROM region. This mode of operation continues until the system issues the Exit HiddenROM command sequence, or until power is removed from the device. On power-up, or following a hardware reset, the device reverts to sending commands to the address.

If you request Fujitsu to program the ESN in the device, please contact a Fujitsu representative for more information.

(2) HiddenROM Entry Command

The device has a HiddenROM region with One Time Protect function. This area is to enter the security code and to unable the change of the code once set. Programming is allowed in this area until it is protected. However, once it gets protected, it is impossible to unprotect. Therefore, extreme caution is required.

The HiddenROM region is 256 bytes / 128 words. This area is in SA0 . Therefore, write the HiddenROM entry command sequence to enter the HiddenROM region. It is called HiddenROM mode when the HiddenROM region appears.

Sectors other than the block area SA0 can be read during HiddenROM mode. Read/program of the HiddenROM region is possible during HiddenROM mode. Write the HiddenROM reset command sequence to exit the HiddenROM mode. Note that any other commands should not be issued than the HiddenROM program/protection/reset commands during the HiddenROM mode. When you issue the other commands including the suspend resume capability, send the HiddenROM reset command first to exit the HiddenROM mode and then issue each command.

(3) HiddenROM Program Command

To program the data to the HiddenROM region, write the HiddenROM program command sequence during HiddenROM mode. This command is the same as the usual program command, except that it needs to write the command during HiddenROM mode. Therefore the detection of completion method is the same as in the past, using the DQ_7 data pooling, DQ_6 Toggle bit or RY/BY. You should pay attention to the address to be programmed. If an address not in the HiddenROM region is selected, the previous data will be deleted. During the write into the HiddenROM region, the program suspend command issuance is prohibited.

(4) HiddenROM Protect Command

There are two methods to protect the HiddenROM region. One is to write the sector group protect setup command (60h) , set the sector address in the HiddenROM region and $(A_6, A_3, A_2, A_1, A_0) = (0, 0, 0, 1, 0)$, and write the sector group protect command (60h) during the HiddenROM mode. The same command sequence may be used because it is the same as the extension sector group protect in the past, except that it is in the HiddenROM mode and does not apply high voltage to the $\overline{\text{RESET}}$ pin. Please refer to above mentioned "Extended Sector Group Protection" for details of sector group protect setting.

The other method is to apply high voltage (V_{ID}) to A_9 and $\overline{\text{OE}}$, set the sector address in the HiddenROM region and $(A_6, A_3, A_2, A_1, A_0) = (0, 0, 0, 1, 0)$, and apply the write pulse during the HiddenROM mode. To verify the protect circuit, apply high voltage (V_{ID}) to A_9 , specify $(A_6, A_3, A_2, A_1, A_0) = (0, 0, 0, 1, 0)$ and the sector address in the HiddenROM region, and read. When "1" appears on DQ_0 , the protect setting is completed. "0" will appear on DQ_0 if it is not protected. Apply write pulse again. The same command sequence could be used for the above method because other than the HiddenROM mode, it is the same as the sector group protect previously mentioned.

MBM29PL12LM₁₀

Take note that other sector groups will be affected if an address other than those for the HiddenROM region is selected for the sector group address. Pay close attention that once it is protected, protection CANNOT BE CANCELLED.

Write Operation Status

Detailed in “Hardware Sequence Flags” are all the status flags which can determine the status of the device for current mode operation. When checking Hardware Sequence Flags during program operations, it should be checked 4 μs after issuing program command. During sector erase, the part provides the status flags automatically to the I/O ports. The information on DQ₂ is address sensitive. If an address from an erasing sector is consecutively read, then the DQ₂ bit will toggle. However DQ₂ will not toggle if an address from a non-erasing sector is consecutively read. This allows the user to determine which sectors are erasing.

Once erase suspend is entered address sensitivity still applies. If the address of a non-erasing sector (one available for read) is provided, then stored data can be read from the device. If the address of an erasing sector (one unavailable for read) is applied, the device will output its status bits.

Hardware Sequence Flags

Status		DQ ₇	DQ ₆	DQ ₅	DQ ₃	DQ ₂	DQ ₁ ^{*3}	
In Progress	Embedded Program Algorithm	\overline{DQ}_7	Toggle	0	0	1	0	
	Embedded Erase Algorithm	0	Toggle	0	1	Toggle ^{*1}	N/A	
	Program Suspend Mode	Program-Suspend-Read (Program Suspended Sector)	Data	Data	Data	Data	Data	Data
		Program-Suspend-Read (Non-Program Suspended Sector)	Data	Data	Data	Data	Data	Data
	Erase Suspend Mode	Erase-Suspend-Read (Erase Suspended Sector)	1	1	0	0	Toggle ^{*1}	N/A
		Erase-Suspend-Read (Non-Erase Suspended Sector)	Data	Data	Data	Data	Data	Data
Erase-Suspend-Program (Non-Erase Suspended Sector)		\overline{DQ}_7	Toggle	0	0	1 ^{*2}	N/A	
Exceeded Time Limits	Embedded Program Algorithm	\overline{DQ}_7	Toggle	1	0	1	N/A	
	Embedded Erase Algorithm	0	Toggle	1	1	N/A	N/A	
	Erase Suspend Mode	Erase-Suspend-Program (Non-Erase Suspended Sector)	\overline{DQ}_7	Toggle	1	0	N/A	N/A
Write to Buffer ^{*4}	BUSY State	\overline{DQ}_7	Toggle	0	N/A	N/A	0	
	Exceeded Timing Limits	\overline{DQ}_7	Toggle	1	N/A	N/A	0	
	ABORT State	N/A	Toggle	0	N/A	N/A	1	

*1 : Successive reads from the erasing or erase-suspend sector will cause DQ₂ to toggle.

*2 : Reading from non-erase suspend sector address will indicate logic “1” at the DQ₂ bit.

*3 : DQ₁ indicates the Write-to-Buffer ABORT status during Write-Buffer-Programming operations.

*4 : The \overline{Data} Polling algorithm detailed in “ \overline{Data} Polling Algorithm” in ■FLOW CHART should be used for Write-Buffer-Programming operations. Note that \overline{DQ}_7 during Write-Buffer-Programming indicates the data-bar for DQ₇ data for the LAST LOADED WRITE-BUFFER ADDRESS location.

DQ₇**Data Polling**

The devices feature $\overline{\text{Data}}$ Polling as a method to indicate to the host that the Embedded Algorithms are in progress or completed. During the Embedded Program Algorithm, an attempt to read devices will produce reverse data last written to DQ₇. Upon completion of the Embedded Program Algorithm, an attempt to read the device will produce true data last written to DQ₇. For programming, the $\overline{\text{Data}}$ Polling is valid after the rising edge of fourth write pulse in the four write pulse sequence. During the Embedded Erase Algorithm, an attempt to read the device will produce a “0” at the DQ₇ output. Upon completion of the Embedded Erase Algorithm, an attempt to read device will produce a “1” at the DQ₇ output. The flowchart for $\overline{\text{Data}}$ Polling (DQ₇) is shown in “Data Polling Algorithm” in ■FLOW CHART.

For chip erase and sector erase, the $\overline{\text{Data}}$ Polling is valid after the rising edge of the sixth write pulse in the six write cycles. $\overline{\text{Data}}$ Polling must be performed at sector addresses of sectors being erased, not protected sectors. Otherwise, the status may become invalid.

If a program address falls within a protected sector, Data polling on DQ₇ is active for approximately 1 μs , then the device returns to read mode. After an erase command sequence is written, if all sectors selected for erasing are protected, $\overline{\text{Data}}$ Polling on DQ₇ is active for approximately 400 μs , then the device returns to read mode. If not all selected sectors are protected, the Embedded Erase algorithm erases the unprotected sectors, and ignores the selected sectors that are protected.

Once the Embedded Algorithm operation is close to being completed, the device data pins (DQ₇) may change asynchronously while the output enable ($\overline{\text{OE}}$) is asserted low. This means that the device is driving status information on DQ₇ at one instant of time, and then that byte's valid data the next. Depending on when the system samples the DQ₇ output, it may read the sequence flag or valid data. Even if the device completes the Embedded Algorithm operation and DQ₇ has a valid data, the data outputs on DQ₆ to DQ₀ may still be invalid. The valid data on DQ₇ to DQ₀ will be read on the successive read attempts.

The $\overline{\text{Data}}$ Polling feature is active only during the Embedded Programming Algorithm, Embedded Erase Algorithm, Erase Suspend mode or sector erase time-out.

See “ $\overline{\text{Data}}$ Polling during Embedded Algorithm Operation Timing Diagram” in ■TIMING DIAGRAM for the $\overline{\text{Data}}$ Polling timing specifications and diagram.

DQ₆**Toggle Bit I**

The device also feature the “Toggle Bit I” as a method to indicate to the host system that the Embedded Algorithms are in progress or completed.

During an Embedded Program or Erase Algorithm cycle, successive attempts to read ($\overline{\text{CE}}$ or $\overline{\text{OE}}$ toggling) data from the devices will result in DQ₆ toggling between 1 and 0. Once the Embedded Program or Erase Algorithm cycle is completed, DQ₆ will stop toggling and valid data will be read on the next successive attempts. During programming, the Toggle Bit I is valid after the rising edge of the fourth write pulse in the four write cycles. For chip erase and sector erase, the Toggle Bit I is valid after the rising edge of the sixth write pulse in the six write cycles. The Toggle Bit I is active during the sector time out.

In programm operation, if the sector being written to is protected, the Toggle bit will toggle for about 1 μs and then stop toggling with the data unchanged. In erase, the device will erase all the selected sectors except for the protected ones. If all selected sectors are protected, the chip will toggle the Toggle bit for about 400 μs and then drop back into read mode, having data kept remained.

Either $\overline{\text{CE}}$ or $\overline{\text{OE}}$ toggling will cause the DQ₆ to toggle. See “Toggle Bit I Timing Diagram during Embedded Algorithm Operations” in ■TIMING DIAGRAM for the Toggle Bit I timing specifications and diagram.

DQ₅

Exceeded Timing Limits

DQ₅ will indicate if the program or erase time has exceeded the specified limits (internal pulse count). Under these conditions DQ₅ will produce a “1”. This is a failure condition indicating that the program or erase cycle was not successfully completed. $\overline{\text{Data}}$ Polling is the only operating function of the device under this condition. The $\overline{\text{CE}}$ circuit will partially power down the device under these conditions (to approximately 2 mA). The $\overline{\text{OE}}$ and $\overline{\text{WE}}$ pins will control the output disable functions as described in “MBM29PL12LM User Bus Operations (Word Mode : $\overline{\text{BYTE}} = V_{\text{IH}}$)” and “MBM29PL12LM User Bus Operations (Byte Mode : $\overline{\text{BYTE}} = V_{\text{IL}}$)” in ■DEVICE BUS OPERATION.

The DQ₅ failure condition may also appear if a user tries to program a non blank location without pre-erase. In this case the device locks out and never completes the Embedded Algorithm operation. Hence, the system never reads a valid data on DQ₇ bit and DQ₆ never stop toggling. Once the device has exceeded timing limits, the DQ₅ bit will indicate a “1”. Note that this is not a device failure condition since the device was incorrectly used. If this occurs, reset the device with command sequence.

DQ₃

Sector Erase Timer

After the completion of the initial sector erase command sequence the sector erase time-out will begin. DQ₃ will remain low until the time-out is complete. $\overline{\text{Data}}$ Polling and Toggle Bit are valid after the initial sector erase command sequence.

If $\overline{\text{Data}}$ Polling or the Toggle Bit I indicates a valid erase command has been written, DQ₃ may be used to determine whether the sector erase timer window is still open. If DQ₃ is “1” the internally controlled erase cycle has begun. If DQ₃ is “0”, the device will accept additional sector erase commands. To insure the command has been accepted, the system software should check the status of DQ₃ prior to and following each subsequent Sector Erase command. If DQ₃ were high on the second status check, the command may not have been accepted.

See “Hardware Sequence Flags”.

DQ₂

Toggle Bit II

This Toggle bit II, along with DQ₆, can be used to determine whether the devices are in the Embedded Erase Algorithm or in Erase Suspend.

Successive reads from the erasing sector will cause DQ₂ to toggle during the Embedded Erase Algorithm. If the devices are in the erase-suspended-read mode, successive reads from the erase-suspended sector will cause DQ₂ to toggle. When the device is in the erase-suspended-program mode, successive reads from the non-erase suspended sector will indicate a logic “1” at the DQ₂ bit.

DQ₆ is different from DQ₂ in that DQ₆ toggles only when the standard program or Erase, or Erase Suspend Program operation is in progress. The behavior of these two status bits, along with that of DQ₇, is summarized as follows:

For example, DQ₂ and DQ₆ can be used together to determine if the erase-suspend-read mode is in progress. (DQ₂ toggles while DQ₆ does not.) See also “Hardware Sequence Flags” and “DQ₂ vs. DQ₆” in ■TIMING DIAGRAM.

Furthermore, DQ₂ can also be used to determine which sector is being erased. At the erase mode, DQ₂ toggles if this bit is read from an erasing sector.

Reading Toggle Bits DQ₆ / DQ₂

Whenever the system initially begins reading Toggle bit status, it must read DQ₇ to DQ₀ at least twice in a row to determine whether a Toggle bit is toggling. Typically a system would note and store the value of the Toggle bit after the first read. After the second read, the system would compare the new value of the Toggle bit with the first. If the Toggle bit is not toggling, the device has completed the program or erase operation. The system can read array data on DQ₇ to DQ₀ on the following read cycle.

However, if, after the initial two read cycles, the system determines that the Toggle bit is still toggling, the system also should note whether the value of DQ₅ is high (see the section on DQ₅) . If it is, the system should then determine again whether the Toggle bit is toggling, since the Toggle bit may have stopped toggling just as DQ₅ went high. If the Toggle bit is no longer toggling, the device has successfully completed the program or erase operation. If it is still toggling, the device did not complete the operation successfully, and the system must write the reset command to return to reading array data.

The remaining scenario is that the system initially determines that the Toggle bit is toggling and DQ₅ has not gone high. The system may continue to monitor the Toggle bit and DQ₅ through successive read cycles, determining the status as described in the previous paragraph. Alternatively, it may choose to perform other system tasks. In this case, the system must start at the beginning of the algorithm when it returns to determine the status of the operation. (Refer to “Toggle Bit Algorithm” in ■FLOW CHART.)

Toggle Bit Status

Mode	DQ ₇	DQ ₆	DQ ₂
Program	\overline{DQ}_7	Toggle	1
Erase	0	Toggle	Toggle *1
Erase-Suspend-Read (Erase-Suspended Sector)	1	1	Toggle *1
Erase-Suspend-Program	\overline{DQ}_7	Toggle	1 *2

*1 : Successive reads from the erasing or erase-suspend sector will cause DQ₂ to toggle.

*2 : Reading from the non-erase suspend sector address will indicate logic “1” at the DQ₂ bit.

DQ₁

Write-to-Buffer Abort

DQ₁ indicates whether a Write-to-Buffer operation was aborted. Under these conditions DQ₁ produces a “1”. The system must issue the Write-to-Buffer-Abort-Reset command sequence to return the device to reading array data. See “Write Buffer Programming Operations” section for more details.

$\overline{RY/BY}$

Ready/Busy

The device provides a $\overline{RY/BY}$ open-drain output pin to indicate to the host system that the Embedded Algorithms are either in progress or has been completed. If the output is low, the device is busy with either a program or erase operation. If the output is high impedance, the device is ready to accept any write or erase operation. If the device is placed in an Erase Suspend mode, the $\overline{RY/BY}$ output will be high, by means of connecting with a pull-up resistor.

During programming, the $\overline{RY/BY}$ pin is driven low after the rising edge of the fourth \overline{WE} pulse. During an erase operation, the $\overline{RY/BY}$ pin is driven low after the rising edge of the sixth \overline{WE} pulse. The $\overline{RY/BY}$ pin will indicate a ready condition during the \overline{RESET} is V_{IL} . See “ $\overline{RY/BY}$ Timing Diagram during Program/Erase Operation Timing Diagram” and “ \overline{RESET} Timing Diagram (During Embedded Algorithms)” in “■TIMING DIAGRAM” for a detailed timing diagram. The $\overline{RY/BY}$ pin is pulled high in standby mode.

Since this is an open-drain output, $\overline{RY/BY}$ pins can be tied together in parallel with a pull-up resistor to V_{CC} .

Word/Byte Configuration

$\overline{\text{BYTE}}$ pin selects the byte (8-bit) mode or word (16-bit) mode for the device. When this pin is driven high, the device operates in the word (16-bit) mode. Data is read and programmed at DQ₁₅ to DQ₀. When this pin is driven low, the device operates in byte (8-bit) mode. In this mode, DQ₁₅/A₋₁ pin becomes the lowest address bit, and DQ₁₄ to DQ₈ bits are High-Z. However, the command bus cycle is always an 8-bit operation and hence commands are written at DQ₇ to DQ₀ and DQ₁₅ to DQ₈ bits are ignored.

Data Protection

The device is designed to offer protection against accidental erasure or programming caused by spurious system level signals that may exist during power transitions. During power up the device automatically reset the internal state machine in Read mode. Also, with its command register architecture, alteration of memory contents only occurs after successful completion of specific multi-bus cycle command sequences.

The device also incorporates several features to prevent inadvertent write cycles resulting from V_{CC} power-up and power-down transitions or system noise.

(1) Low V_{CC} Write Inhibit

To avoid initiation of a write cycle during V_{CC} power-up and power-down, a write cycle is locked out for V_{CC} less than V_{LKO}. If V_{CC} < V_{LKO}, the command register is disabled and all internal program/erase circuits are disabled. Under this condition, the device will reset to the read mode. Subsequent writes will be ignored until the V_{CC} level is greater than V_{LKO}. It is the user's responsibility to ensure that the control pins are logically correct to prevent unintentional writes when V_{CC} is above V_{LKO}.

If Embedded Erase Algorithm is interrupted, the intervened erasing sector(s) is(are) not valid.

(2) Write Pulse "Glitch" Protection

Noise pulses of less than 3 μs (typical) on $\overline{\text{OE}}$, $\overline{\text{CE}}$, or $\overline{\text{WE}}$ will not initiate a write cycle.

(3) Logical Inhibit

Writing is inhibited by holding any one of $\overline{\text{OE}} = V_{\text{IL}}$, $\overline{\text{CE}} = V_{\text{IH}}$, or $\overline{\text{WE}} = V_{\text{IH}}$. To initiate a write, $\overline{\text{CE}}$ and $\overline{\text{WE}}$ must be low while $\overline{\text{OE}}$ is high.

(4) Power-up Write Inhibit

Power-up of the devices with $\overline{\text{WE}} = \overline{\text{CE}} = V_{\text{IL}}$ and $\overline{\text{OE}} = V_{\text{IH}}$ will not accept commands on the rising edge of $\overline{\text{WE}}$. The internal state machine is automatically set to read mode on power-up.

(5) Sector Protection

Device is able to protect each sector group to store and protect data in the user side. Protection circuit voids both write and erase commands that are addressed to protected sectors.

Any commands to write or erase addressed to protected sector are ignored.

See "Sector Group Protection" in ■FUNCTIONAL DESCRIPTION.

■ ABSOLUTE MAXIMUM RATINGS

Parameter	Symbol	Rating		Unit
		Min	Max	
Storage Temperature	T _{stg}	-55	+125	°C
Ambient Temperature with Power Applied	T _A	-20	+85	°C
Voltage with Respect to Ground All Pins Except A ₉ , $\overline{\text{OE}}$, and $\overline{\text{RESET}}$ *1,*2	V _{IN} , V _{OUT}	-0.5	V _{CC} +0.5	V
Power Supply Voltage *1	V _{CC}	-0.5	+4.0	V
A ₉ , $\overline{\text{OE}}$, and $\overline{\text{RESET}}$ *1,*3	V _{IN}	-0.5	+12.5	V
$\overline{\text{WP/ACC}}$ *1,*3	V _{ACC}	-0.5	+12.5	V

*1 : Voltage is defined on the basis of V_{SS} = GND = 0 V.

*2 : Minimum DC voltage on input or I/O pins is -0.5 V. During voltage transitions, input or I/O pins may undershoot V_{SS} to -0.2 V for periods of up to 20 ns. Maximum DC voltage on input or I/O pins is V_{CC} +0.5 V. During voltage transitions, input or I/O pins may overshoot to V_{CC} +2.0 V for periods of up to 20 ns

*3 : Minimum DC input voltage is -0.5V. During voltage transitions, these pins may undershoot V_{SS} to -0.2 V for periods of up to 20 ns. Voltage difference between input and supply voltage (V_{IN}-V_{CC}) dose not exceed to +9.0 V. Maximum DC input voltage is +12.5 V which may overshoot to +14.0 V for periods of up to 20 ns .

WARNING: Semiconductor devices can be permanently damaged by application of stress (voltage, current, temperature, etc.) in excess of absolute maximum ratings. Do not exceed these ratings.

■ RECOMMENDED OPERATING RANGES*1

Parameter	Symbol	Value		Unit
		Min	Max	
Ambient Temperature	T _A	-20	+85	°C
V _{CC} Supply Voltage *2, *3	V _{CC}	+3.0	+3.6	V
V _{CCQ} Supply Voltage *2, *3	V _{CCQ}	V _{CC}		V

*1 : Operating ranges define those limits between which the functionality of the device is guaranteed.

*2 : Voltage is defined on the basis of V_{SS} = GND = 0V.

*3 : See if V_{CC} and V_{CCQ} are of the same value.

WARNING: The recommended operating conditions are required in order to ensure the normal operation of the semiconductor device. All of the device's electrical characteristics are warranted when the device is operated within these ranges.

Always use semiconductor devices within their recommended operating condition ranges. Operation outside these ranges may adversely affect reliability and could result in device failure.

No warranty is made with respect to uses, operating conditions, or combinations not represented on the data sheet. Users considering application outside the listed conditions are advised to contact their FUJITSU representatives beforehand.

■ MAXIMUM OVERSHOOT/MAXIMUM UNDERSHOOT

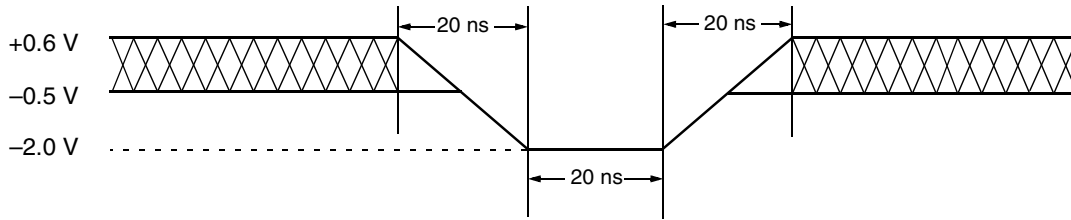

Maximum Undershoot Waveform

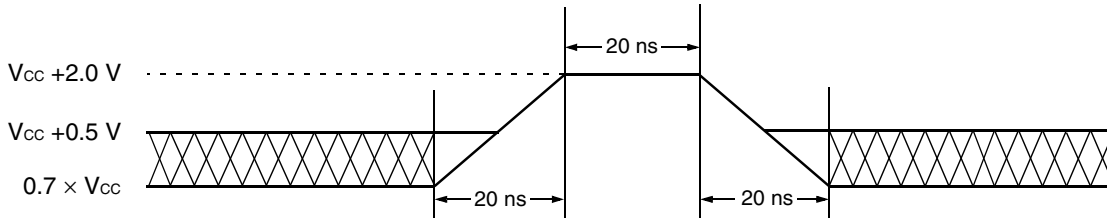

Maximum Overshoot Waveform 1

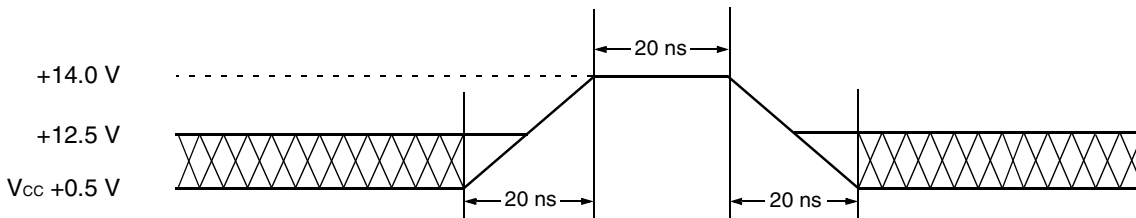

Note: This waveform is applied for A_9 , \overline{OE} , \overline{RESET} , and $\overline{WP/ACC}$.

Maximum Overshoot Waveform 2

■ ELECTRICAL CHARACTERISTICS

1. DC Characteristics

Parameter	Symbol	Conditions	Value			Unit	
			Min	Typ	Max		
Input Leakage Current	I _{LI}	V _{IN} = V _{SS} to V _{CC} , V _{CC} = V _{CC} Max	\overline{WP}/ACC pin	-2.0	—	+2.0	μA
			Others	-1.0	—	+1.0	
Output Leakage Current	I _{LO}	V _{OUT} = V _{SS} to V _{CC} , V _{CC} = V _{CC} Max	-1.0	—	+1.0	μA	
A ₉ , \overline{OE} , \overline{RESET} Inputs Leakage Current	I _{LIT}	V _{CC} = V _{CC} Max, A ₉ , \overline{OE} , \overline{RESET} = 12.5 V	—	—	35	μA	
V _{CC} Active Current (Read) *1,*2	I _{CC1}	\overline{CE} = V _{IL} , \overline{OE} = V _{IH} , f = 5 MHz	Word	—	15	25	mA
			Byte	—	15	25	
		\overline{CE} = V _{IL} , \overline{OE} = V _{IH} , f = 10 MHz	Word	—	35	50	
			Byte	—	35	50	
V _{CC} Active Current (Intra-Page Read) *2	I _{CC2}	\overline{CE} = V _{IL} , \overline{OE} = V _{IH} , t _{PRC} = 25ns, 4-Word	—	10	20	mA	
V _{CC} Active Current (Program / Erase) *2,*3	I _{CC3}	\overline{CE} = V _{IL} , \overline{OE} = V _{IH}	—	50	60	mA	
V _{CC} Standby Current *2	I _{CC4}	\overline{CE} = V _{CC} ± 0.3 V, \overline{RESET} = V _{CC} ± 0.3 V, \overline{OE} = V _{IH} , \overline{WP}/ACC = V _{CC} ± 0.3 V	—	1	5	μA	
V _{CC} Reset Current *2	I _{CC5}	\overline{RESET} = V _{CC} ± 0.3 V, \overline{WP}/ACC = V _{CC} ± 0.3 V	—	1	5	μA	
V _{CC} Automatic Sleep Current *4	I _{CC6}	\overline{CE} = V _{SS} ± 0.3 V, \overline{RESET} = V _{CC} ± 0.3 V, V _{IN} = V _{CC} ± 0.3V or V _{SS} ± 0.3V, \overline{WP}/ACC = V _{CC} ± 0.3 V	—	1	5	μA	
V _{CC} Active Current (Erase-Suspend-Program) *2	I _{CC7}	\overline{CE} = V _{IL} , \overline{OE} = V _{IH}	—	50	60	mA	
ACC Accelerated Program Current	I _{ACC}	\overline{CE} = V _{IL} , \overline{OE} = V _{IH} , V _{CC} = V _{CC} Max, \overline{WP}/ACC = V _{ACC} Max	\overline{WP}/ACC pin	—	—	45	mA
			V _{CC} Pin	—	—	60	
Input Low Level	V _{IL}	—	-0.5	—	0.6	V	
Input High Level	V _{IH}	—	0.7×V _{CC}	—	V _{CC} + 0.3	V	
Voltage for \overline{WP}/ACC Sector Protection/Unprotection and Program Acceleration	V _{ACC}	V _{CC} = 3.0 V to 3.6 V	11.5	12.0	12.5	V	
Voltage for Autoselect, and Temporary Sector Unprotected	V _{ID}	V _{CC} = 3.0 V to 3.6 V	11.5	12.0	12.5	V	
Output Low Voltage Level	V _{OL}	I _{OL} = 4.0 mA, V _{CC} = V _{CC} Min	—	—	0.45	V	
Output High Voltage Level	V _{OH}	I _{OH} = -2.0 mA, V _{CC} = V _{CC} Min	0.85×V _{CCQ}	—	—	V	
Low V _{CC} Lock-Out Voltage	V _{LKO}	—	2.3	—	2.5	V	

MBM29PL12LM₁₀

- *1 : The I_{CC} current listed includes both the DC operating current and the frequency dependent component.
- *2 : I_{CC} peaks when both V_{CC} and V_{CCQ} are at their Max.
- *3 : I_{CC} active while Embedded Erase or Embedded Program or Write Buffer Programming is in progress.
- *4 : Automatic sleep mode enables the low power mode when address remain stable for $t_{ACC} + 30$ ns.

2. AC Characteristics

• Read Only Operations Characteristics

Parameter	Symbols		Condition	Value*		Unit
	JEDEC	Standard		10		
				Min	Max	
Read Cycle Time	t _{AVAV}	t _{RC}	—	100	—	ns
Address to Output Delay	t _{AVQV}	t _{ACC}	$\overline{CE} = V_{IL},$ $\overline{OE} = V_{IL}$	—	100	ns
Chip Enable to Output Delay	t _{ELQV}	t _{CE}	$\overline{OE} = V_{IL}$	—	100	ns
Page Read Cycle Time	—	t _{PRC}	—	25	—	ns
Page Address to Output Delay	—	t _{PACC}	$\overline{CE} = V_{IL},$ $\overline{OE} = V_{IL}$	—	30	ns
Output Enable to Output Delay	t _{GLQV}	t _{OE}	—	—	30	ns
Chip Enable to Output High-Z	t _{EHQZ}	t _{DF}	—	—	25	ns
Output Enable Hold Time	Read	t _{OEH}	—	0	—	ns
	Toggle and \overline{Data} Polling		—	10	—	ns
Output Enable to Output High-Z	t _{GHQZ}	t _{DF}	—	—	25	ns
Output Hold Time From Addresses, \overline{CE} or \overline{OE} , Whichever Occurs First	t _{AXQX}	t _{OH}	—	0	—	ns
\overline{RESET} Pin Low to Read Mode	—	t _{READY}	—	—	20	μs

* : Test Conditions :

- Output Load : 1 TTL gate and 30 pF
- Input rise and fall times : 5 ns
- Input pulse levels : 0.0 V or V_{CC}
- Timing measurement reference level
- Input : V_{CC} / 2
- Output : V_{CC} / 2

• Output load circuit

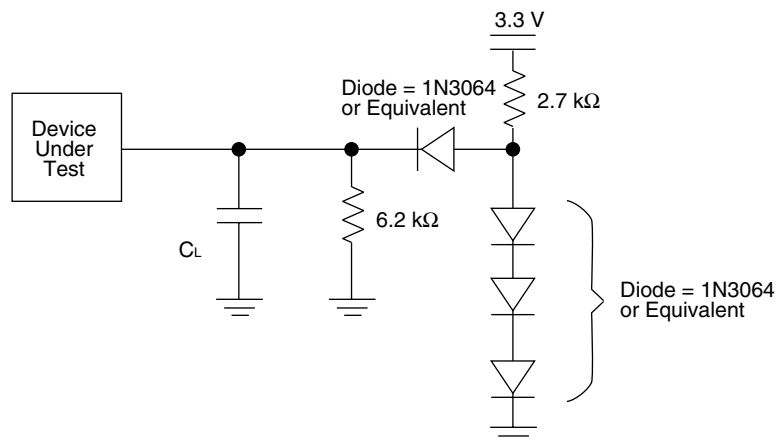

Test Conditions

MBM29PL12LM₁₀

• Write (Erase/Program) Operations

Parameter	Symbol		Value			Unit
			10			
	JEDEC	Standard	Min	Typ	Max	
Write Cycle Time	t _{AVAV}	t _{WC}	100	—	—	ns
Address Setup Time	t _{AVWL}	t _{AS}	0	—	—	ns
Address Setup Time to \overline{OE} Low During Toggle Bit Polling	—	t _{ASO}	15	—	—	ns
Address Hold Time	t _{WLAX}	t _{AH}	45	—	—	ns
Address Hold Time from \overline{CE} or \overline{OE} High During Toggle Bit Polling	—	t _{AHT}	0	—	—	ns
Data Setup Time	t _{DVWH}	t _{DS}	45	—	—	ns
Data Hold Time	t _{WHDX}	t _{DH}	0	—	—	ns
Output Enable Setup Time	—	t _{OES}	0	—	—	ns
\overline{CE} High During Toggle Bit Polling	—	t _{CEPH}	20	—	—	ns
\overline{OE} High During Toggle Bit Polling	—	t _{OEPH}	20	—	—	ns
Read Recover Time Before Write (\overline{OE} High to \overline{WE} Low)	t _{GHWL}	t _{GHWL}	0	—	—	ns
Read Recover Time Before Write (\overline{OE} High to \overline{CE} Low)	t _{GHEL}	t _{GHEL}	0	—	—	ns
\overline{CE} Setup Time	t _{ELWL}	t _{CS}	0	—	—	ns
\overline{WE} Setup Time	t _{WLEL}	t _{WS}	0	—	—	ns
\overline{CE} Hold Time	t _{WHEH}	t _{CH}	0	—	—	ns
\overline{WE} Hold Time	t _{EHWH}	t _{WH}	0	—	—	ns
\overline{CE} Pulse Width	t _{ELEH}	t _{CP}	35	—	—	ns
Write Pulse Width	t _{WLWH}	t _{WP}	35	—	—	ns
\overline{CE} Pulse Width High	t _{EHEL}	t _{CPH}	25	—	—	ns
Write Pulse Width High	t _{WHWL}	t _{WPH}	30	—	—	ns
Effective Page Programming Time (Write Buffer Programming)	Per Word	t _{WHWH1}	—	23.5	—	μ s
Programming Time						
Sector Erase Operation *1	t _{WHWH2}	t _{WHWH2}	—	1.0	—	s
V _{CC} Setup Time	—	t _{VCS}	50	—	—	μ s
Recovery Time From RY/ \overline{BY}	—	t _{PB}	0	—	—	ns
Erase/Program Valid to RY/ \overline{BY} Delay	—	t _{BUSY}	—	—	90	ns
Rise Time to V _{ID} *2	—	t _{VIDR}	500	—	—	ns
Rise Time to V _{ACC} *3	—	t _{VACCR}	500	—	—	ns
Voltage Transition Time *2	—	t _{VLHT}	4	—	—	μ s

(Continued)

(Continued)

Parameter	Symbol		Value			Unit
			10			
	JEDEC	Standard	Min	Typ	Max	
Write Pulse Width *2	—	t _{WPP}	100	—	—	μs
\overline{OE} Setup Time to \overline{WE} Active *2	—	t _{OESP}	4	—	—	μs
\overline{CE} Setup Time to \overline{WE} Active *2	—	t _{CSP}	4	—	—	μs
\overline{RESET} Pulse Width	—	t _{RP}	500	—	—	ns
\overline{RESET} High Time Before Read	—	t _{RH}	100	—	—	ns
Delay Time from Embedded Output Enable	—	t _{EOE}	—	—	100	ns
Erase Time-out Time	—	t _{TOW}	50	—	—	μs
Erase Suspend Transition Time	—	t _{SPD}	—	—	20	μs

*1 : This does not include the preprogramming time.

*2 : This timing is for Sector Group Protection operation.

*3 : This timing is for Accelerated Program operation.

MBM29PL12LM₁₀

■ ERASE AND PROGRAMMING PERFORMANCE

Parameter	Limits			Unit	Remarks
	Min	Typ	Max		
Sector Erase Time	—	1	15	s	Excludes programming time prior to erasure
Programming Time	—	100	3000	μs	Excludes system-level overhead
Effective Page Programming Time (Write Buffer Programming)	—	23.5	—	μs	
Chip Programming Time	—	—	1200	s	
Absolute Maximum Programming Time (16 words)	—	—	6	ms	Non programming within the same page
Erase/Program Cycle	100,000	—	—	cycle	—

■ TSOP (1) PIN CAPACITANCE

Parameter	Symbol	Test Setup	Value		Unit
			Typ	Max	
Input Capacitance	C _{IN}	V _{IN} = 0	8	10	pF
Output Capacitance	C _{OUT}	V _{OUT} = 0	8.5	12	pF
Control Pin Capacitance	C _{IN2}	V _{IN} = 0	8	10	pF
Reset pin and \overline{WP}/ACC Pin Capacitance	C _{IN3}	V _{IN} = 0	20	25	pF

Notes : • Test conditions T_A = +25°C, f = 1.0 MHz
 • DQ₁₅/A-1 pin capacitance is stipulated by output capacitance.



■ FBGA PIN CAPACITANCE

Parameter	Symbol	Test Setup	Value		Unit
			Typ	Max	
Input Capacitance	C _{IN}	V _{IN} = 0	8	10	pF
Output Capacitance	C _{OUT}	V _{OUT} = 0	8.5	12	pF
Control Pin Capacitance	C _{IN2}	V _{IN} = 0	8	10	pF
Reset pin and \overline{WP}/ACC Pin Capacitance	C _{IN3}	V _{IN} = 0	15	20	pF

Notes : • Test conditions T_A = +25°C, f = 1.0 MHz
 • DQ₁₅/A-1 pin capacitance is stipulated by output capacitance.

■ TIMING DIAGRAM

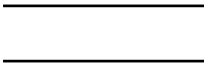
- Key to Switching Waveforms

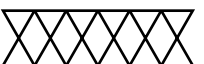
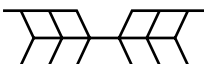
WAVEFORM	INPUTS	OUTPUTS
	Must Be Steady	Will Be Steady
	May Change from H to L	Will Be Changing from H to L
	May Change from L to H	Will Be Changing from L to H
	"H" or "L" Any Change Permitted	Changing State Unknown
	Does Not Apply	Center Line is High-Impedance "Off" State

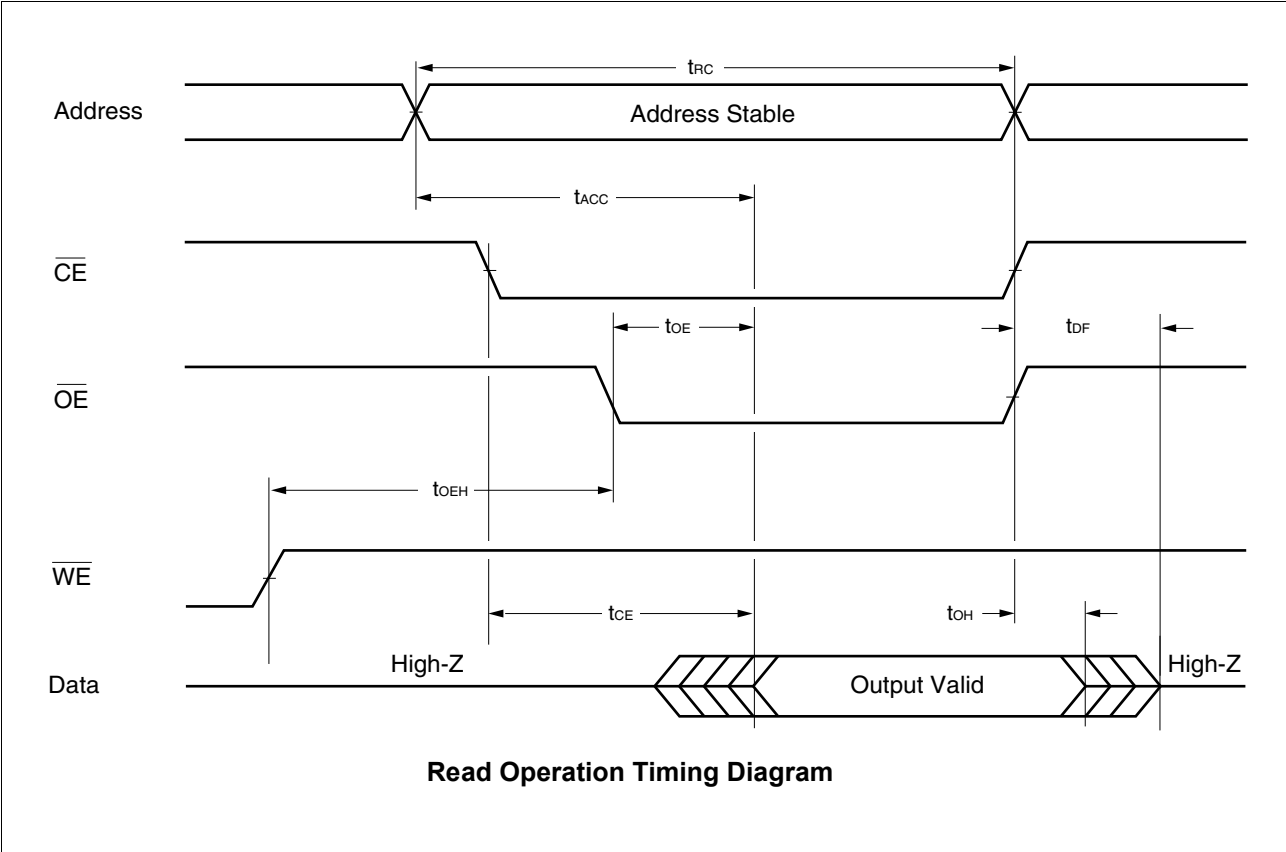

MBM29PL12LM₁₀

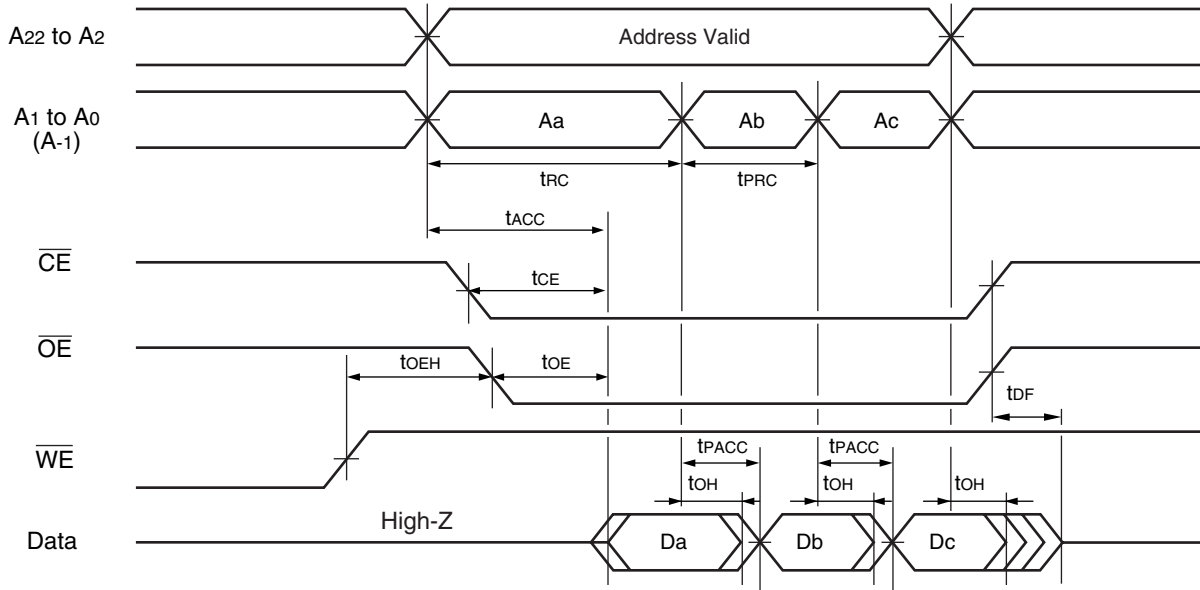

Page Read Operation Timing Diagram

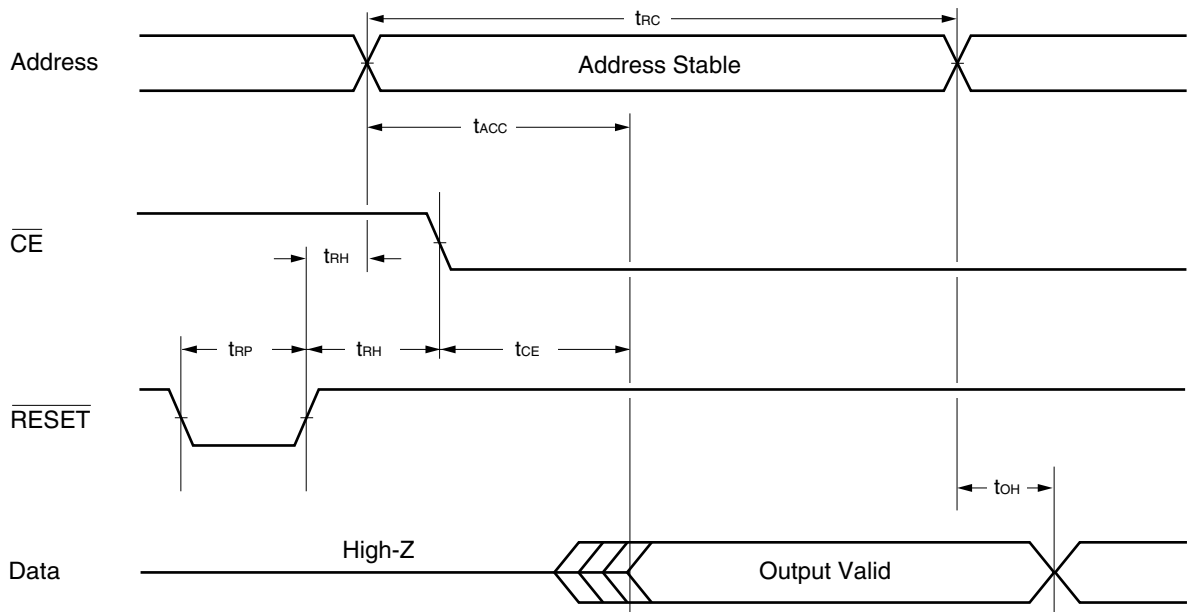

Hardware Reset/Read Operation Timing Diagram

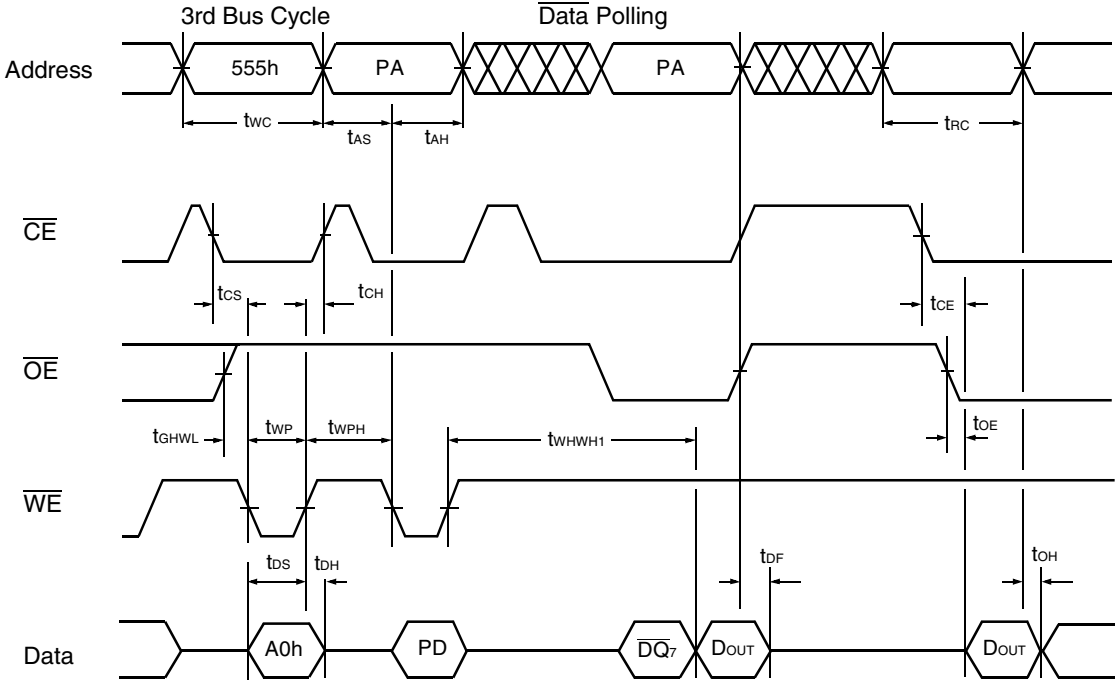

- Notes :
- PA is address of the memory location to be programmed.
 - PD is data to be programmed at word address.
 - \overline{DQ}_7 is the output of the complement of the data written to the device.
 - D_{OUT} is the output of the data written to the device.
 - Figure indicates the last two bus cycles out of four bus cycle sequence.

Alternate \overline{WE} Controlled Program Operation Timing Diagram

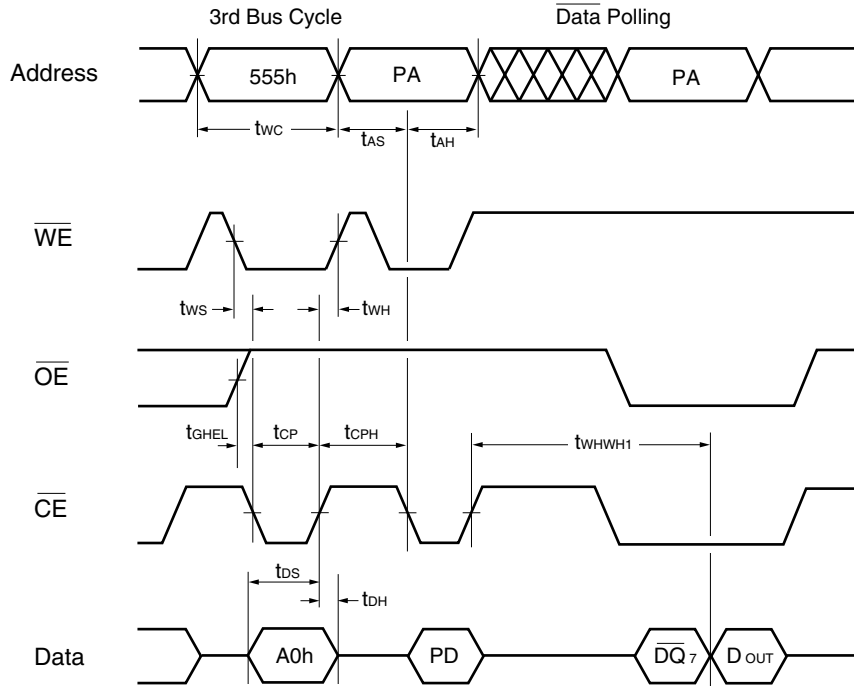

- Notes :
- PA is address of the memory location to be programmed.
 - PD is data to be programmed at word address.
 - \overline{DQ}_7 is the output of the complement of the data written to the device.
 - D_{OUT} is the output of the data written to the device.
 - Figure indicates the last two bus cycles out of four bus cycle sequence.

Alternate \overline{CE} Controlled Program Operation Timing Diagram

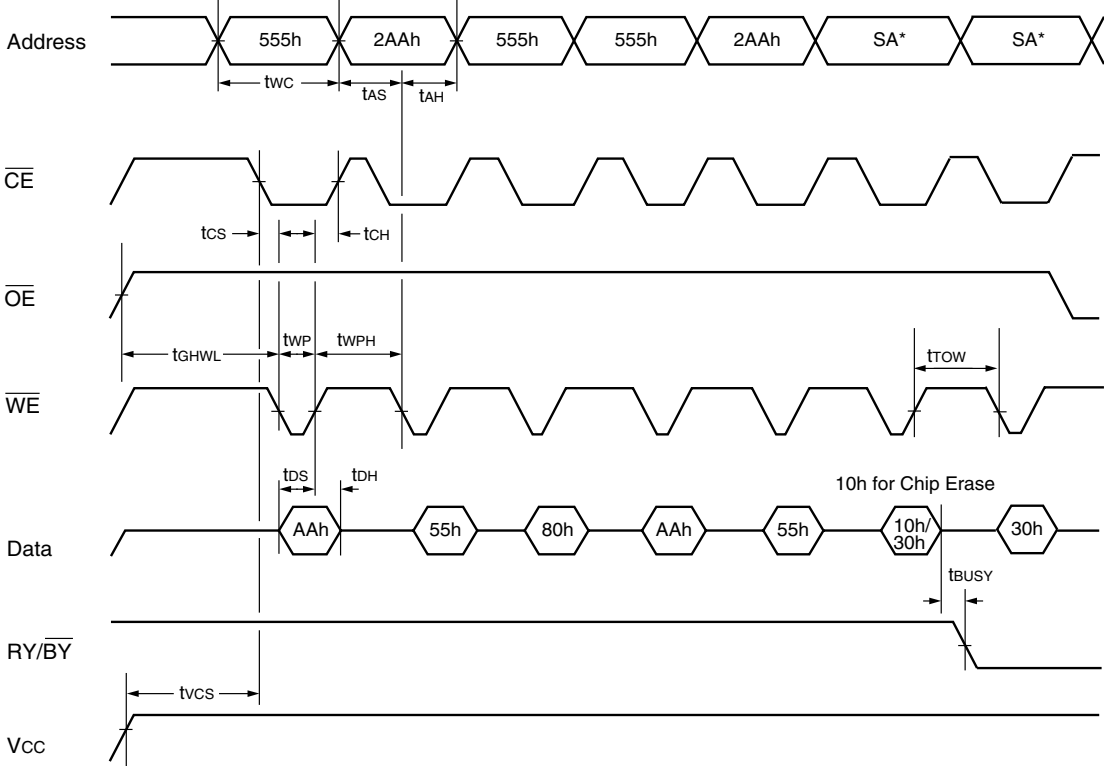

* : SA is the sector address for Sector Erase. Address = 555h (Word), AAh (Byte) for Chip Erase.

Chip/Sector Erase Operation Timing Diagram

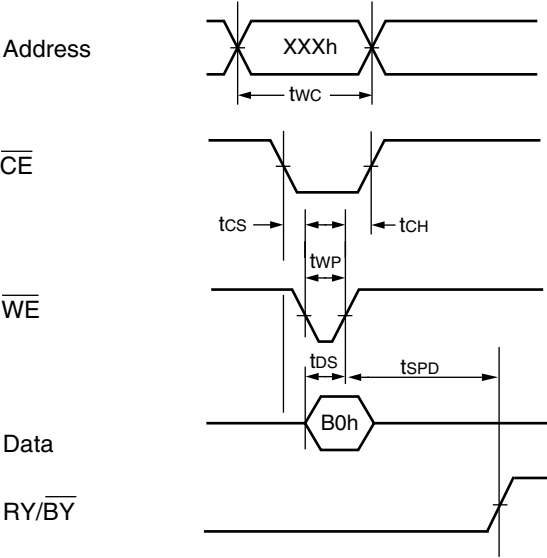

Erase Suspend Operation Timing Diagram

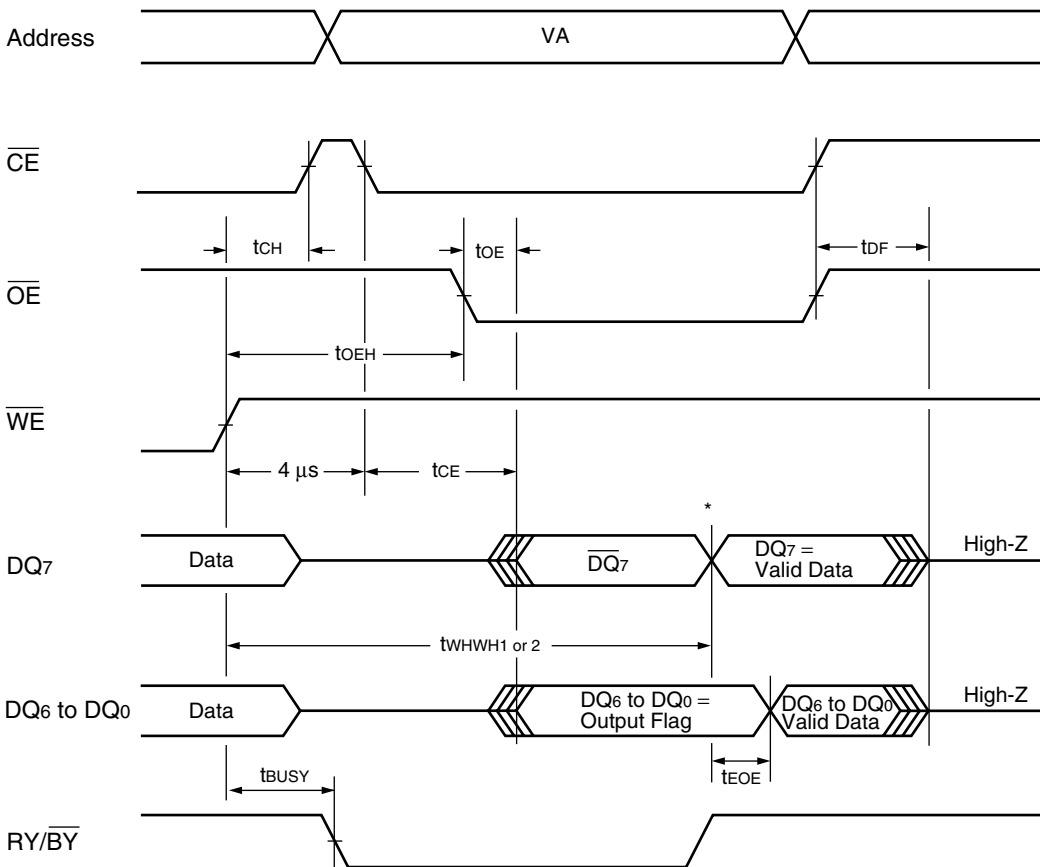

* : $DQ_7 = \text{Valid Data}$ (The device has completed the Embedded operation.)

Note : When checking Hardware Sequence Flags during program operations, it should be checked $4 \mu s$ after issuing program command.

Data Polling during Embedded Algorithm Operation Timing Diagram

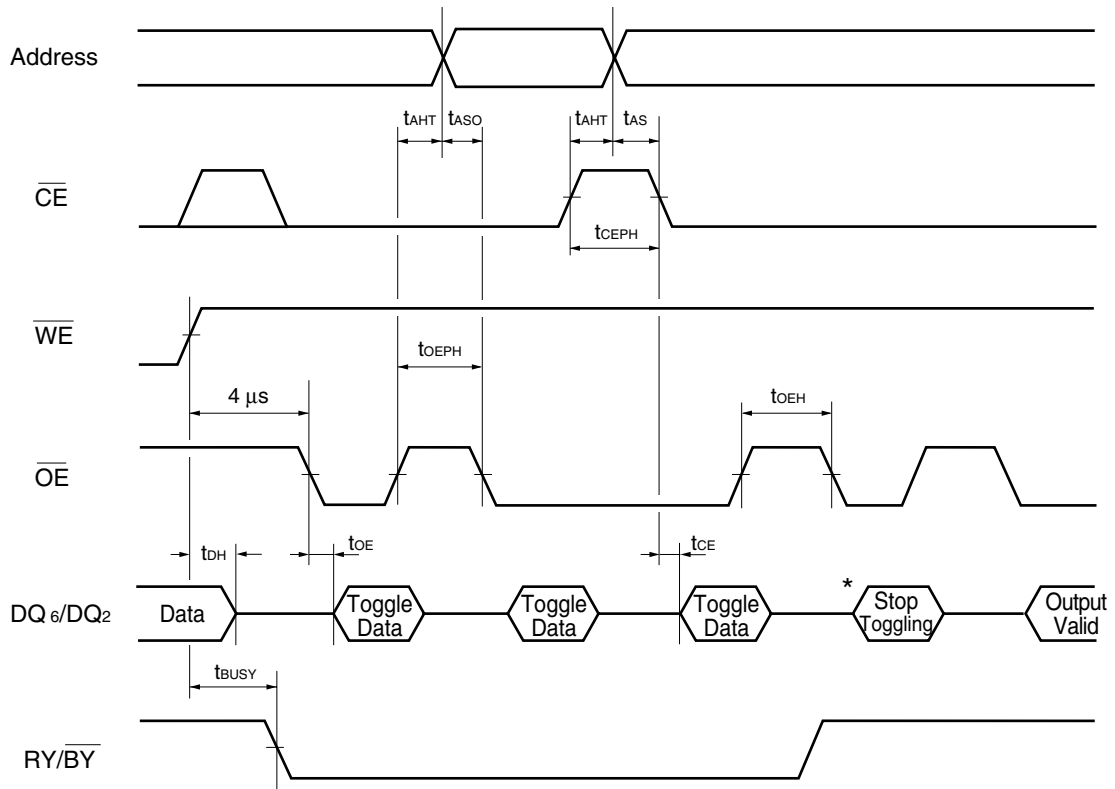

* : DQ_6 stops toggling (The device has completed the Embedded operation).

Note : When checking Hardware Sequence Flags during program operations, it should be checked 4 μ s after issuing program command.

Toggle Bit Timing Diagram during Embedded Algorithm Operations

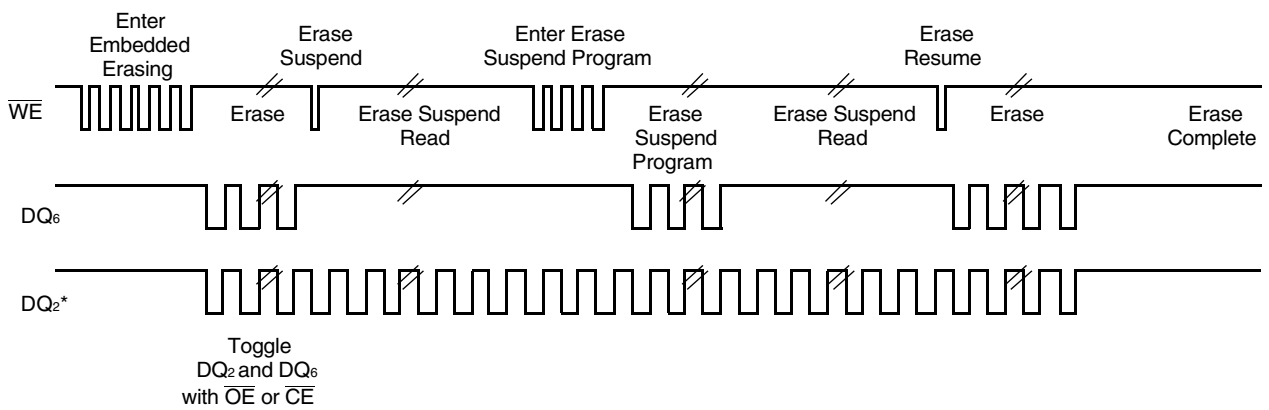

* : DQ_2 is read from the erase-suspended sector.

DQ_2 vs. DQ_6

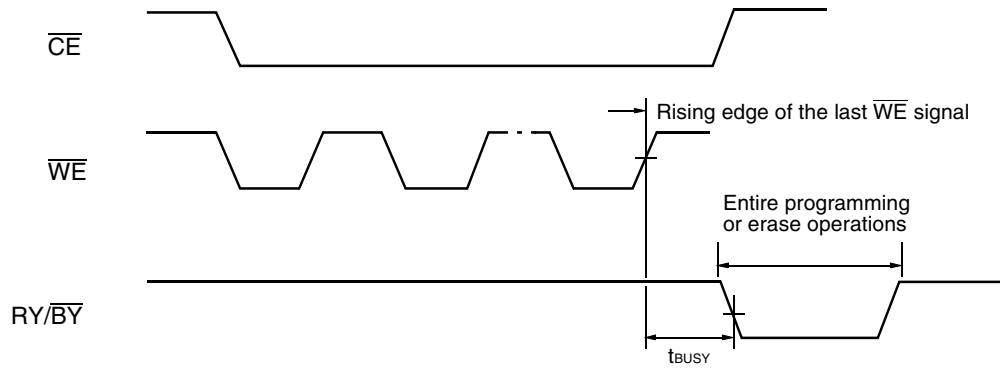

RY/\overline{BY} Timing Diagram during Program/Erase Operation Timing Diagram

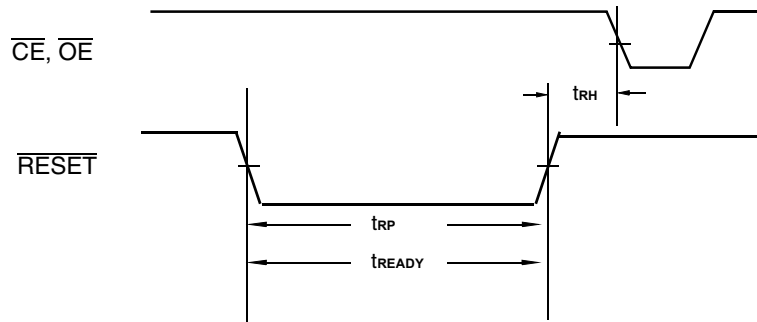

\overline{RESET} Timing Diagram (Not during Embedded Algorithms)

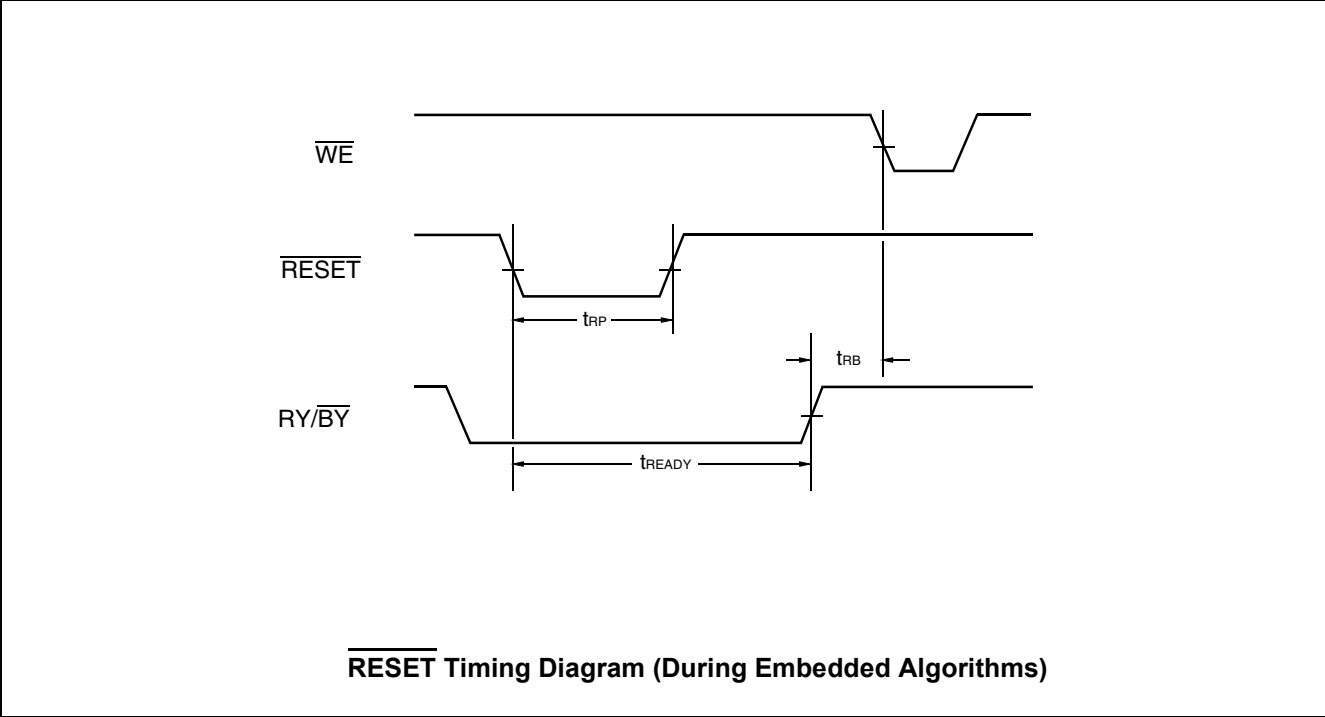

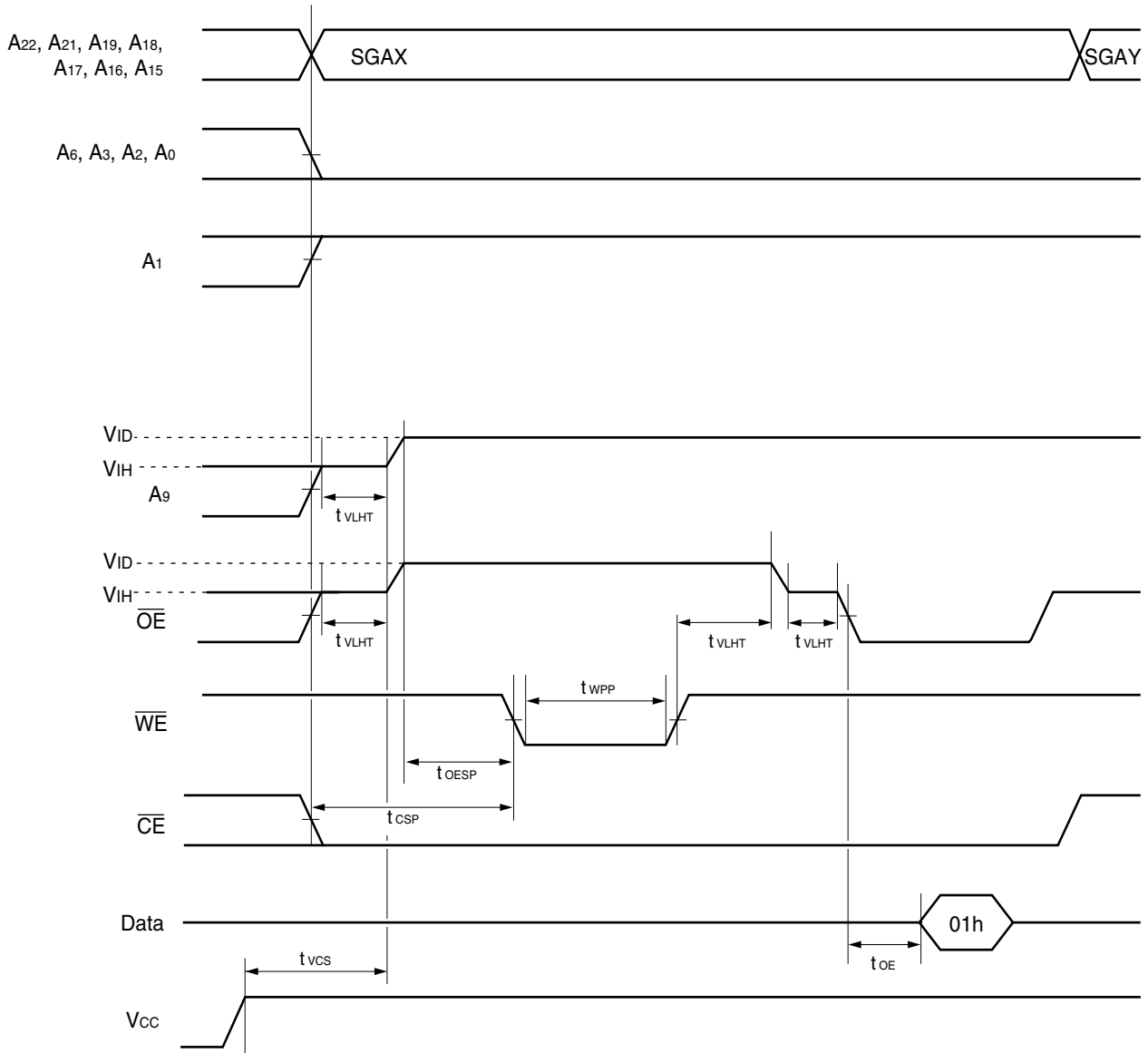

SGAX : Sector Group Address to be protected
 SGAY : Next Sector Group Address to be protected

Sector Group Protection Timing Diagram

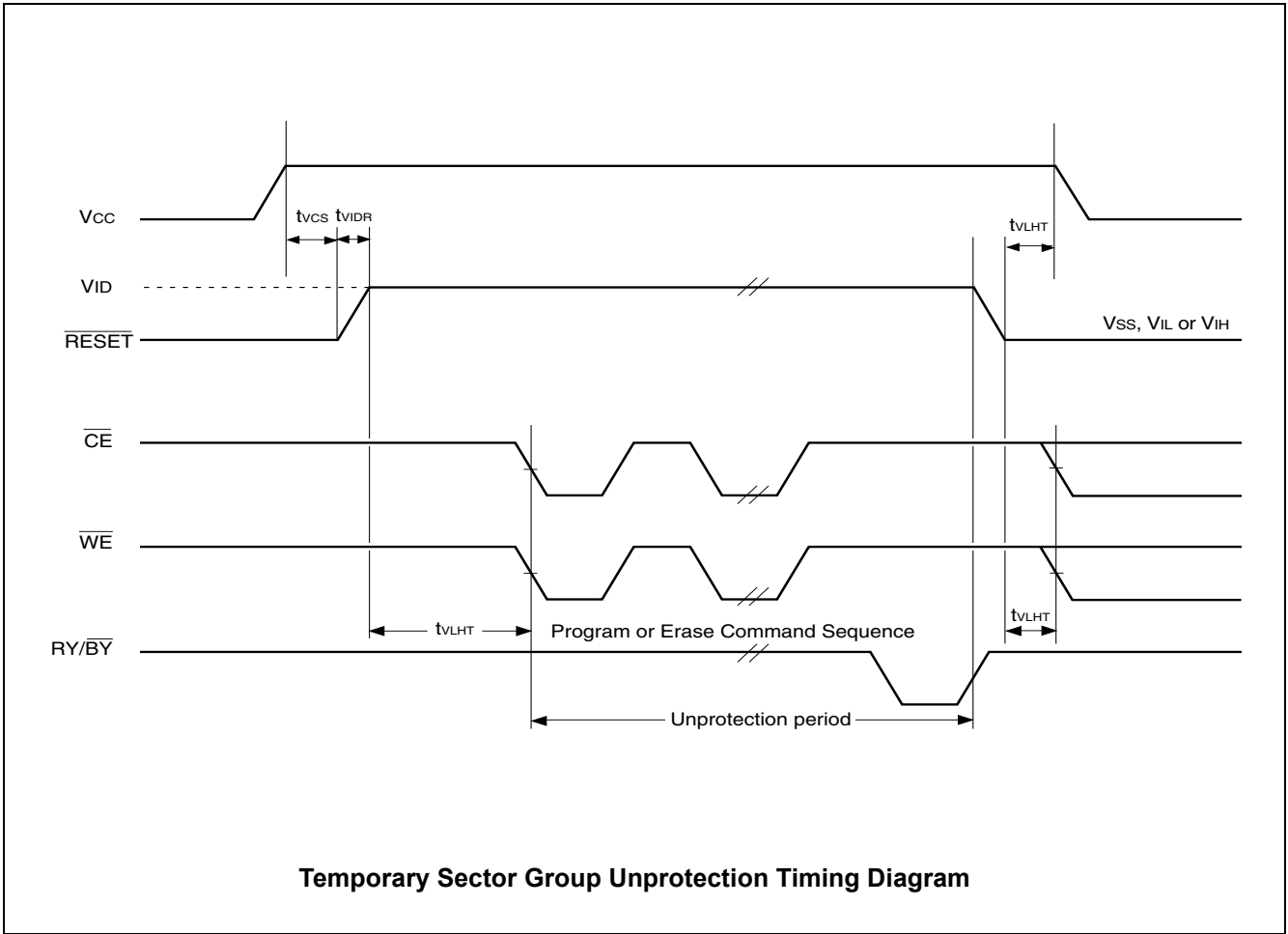

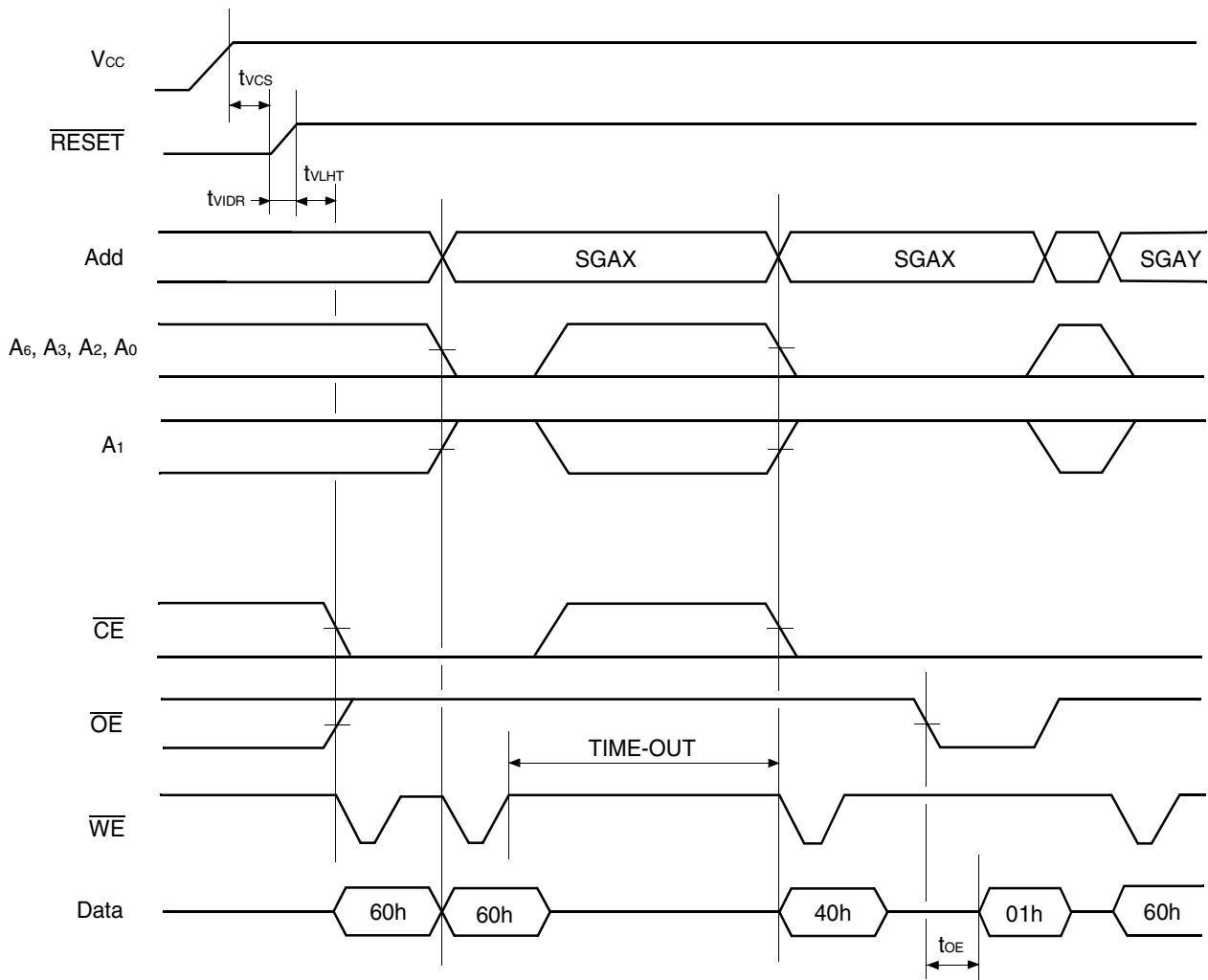

SGAX: Sector Group Address to be protected
 SGAY : Next Sector Group Address to be protected
 TIME-OUT : Time-Out window = 250 μs (Min)

Extended Sector Group Protection Timing Diagram

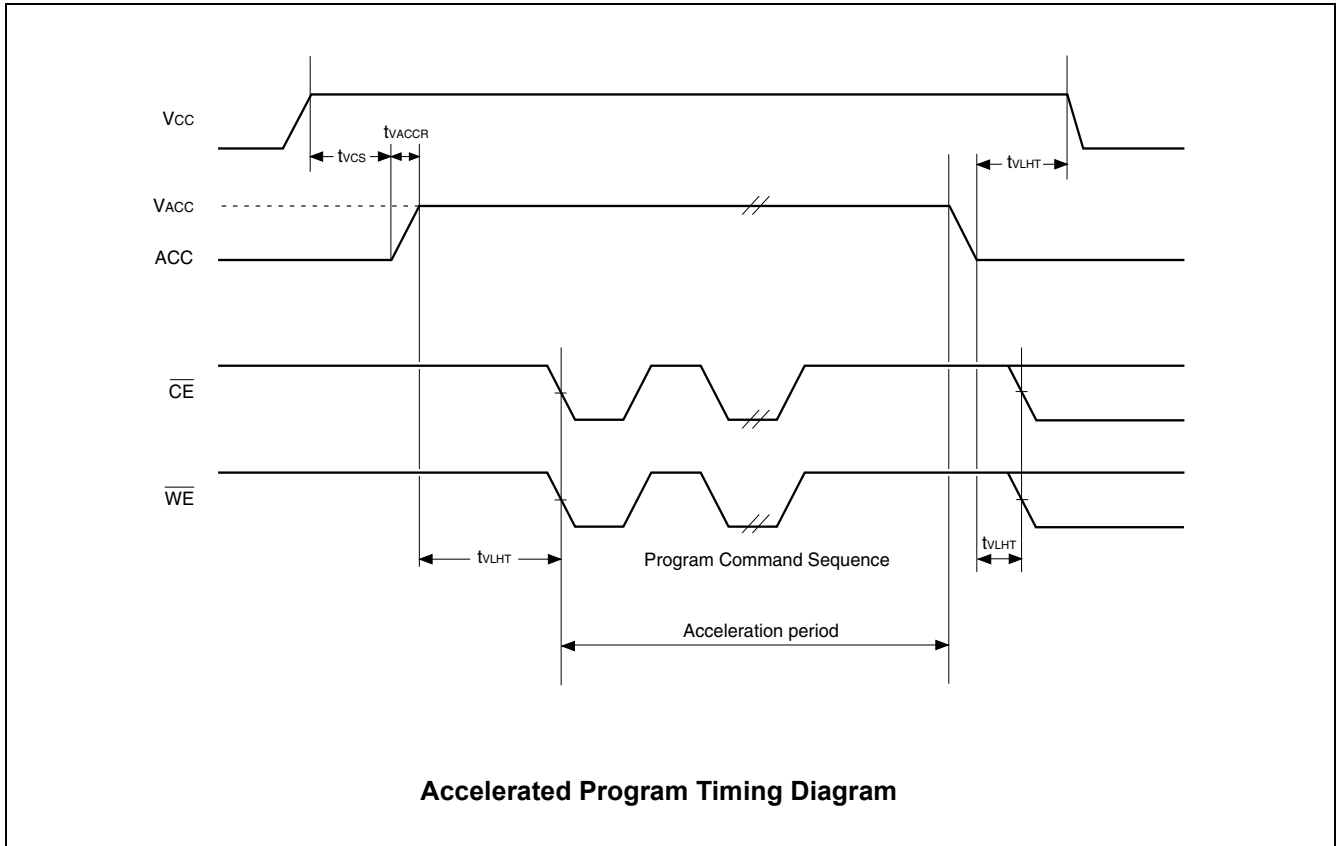

■ FLOW CHART

EMBEDDED ALGORITHMS

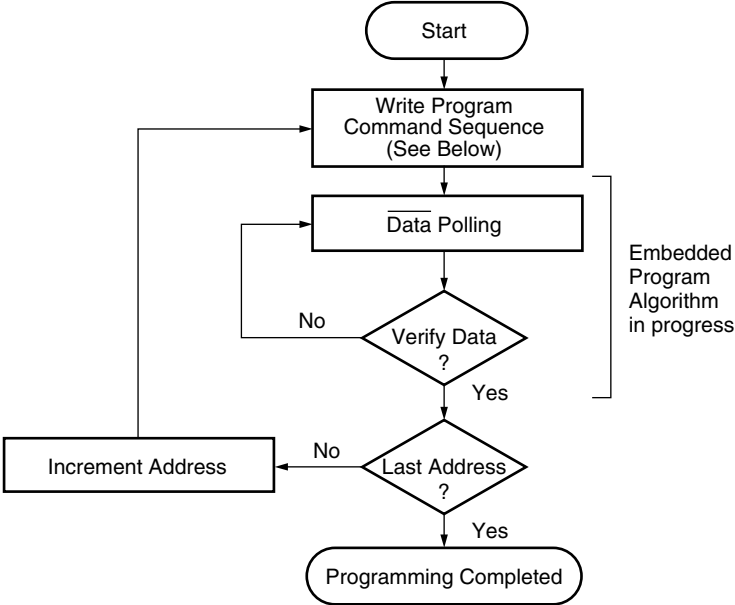

Program Command Sequence (Address/Command):

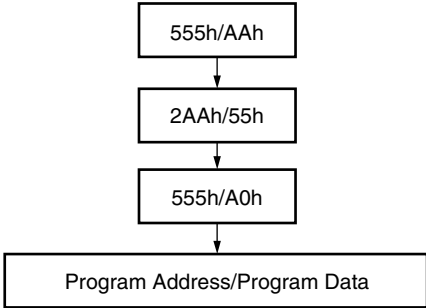

Note : The sequence is applied for Word (×16) mode.
The addresses differ from Byte (× 8) mode.

Embedded Program™ Algorithm

EMBEDDED ALGORITHMS

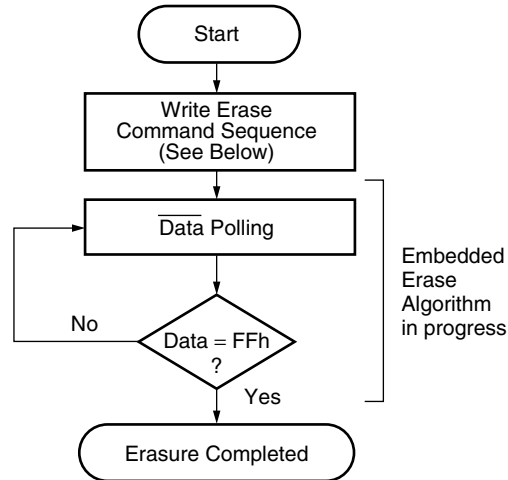

Chip Erase Command Sequence
(Address/Command):

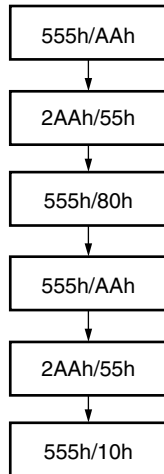

Individual Sector/Multiple Sector
Erase Command Sequence
(Address/Command):

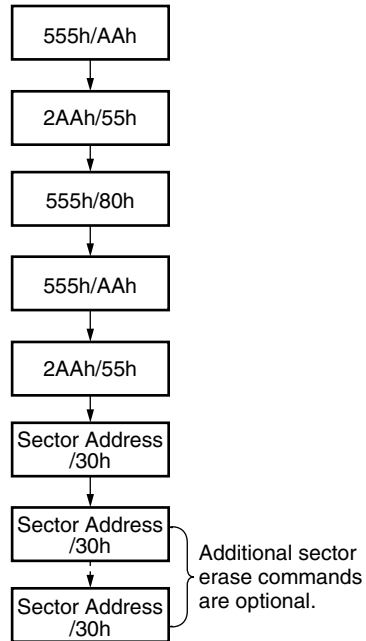

Note : The sequence is applied for Word (× 16) mode.
The addresses differ from Byte (× 8) mode.

Embedded Erase™ Algorithm

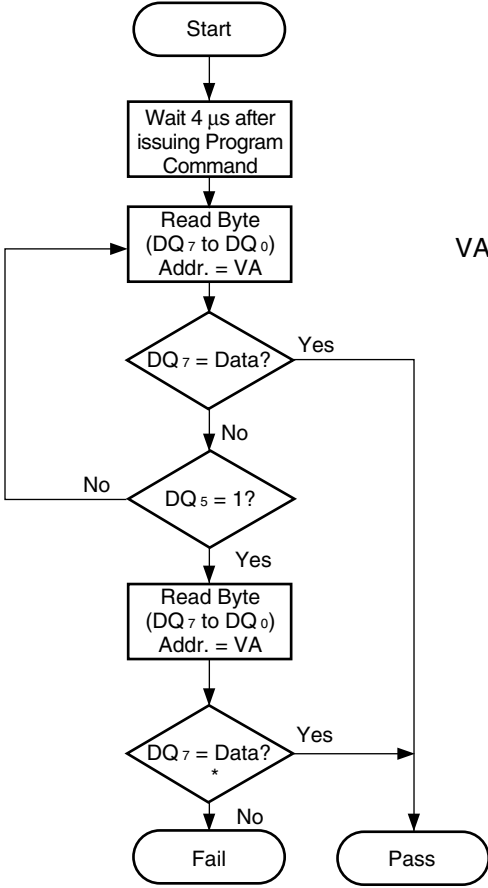

VA = Valid address for programming
= Any of the sector addresses within the sector being erased during sector erase or multiple sector erases operation
= Any of the sector addresses within the sector not being protected during chip erase operation

* : DQ₇ is rechecked even if DQ₅ = "1" because DQ₇ may change simultaneously with DQ₅.

Data Polling Algorithm

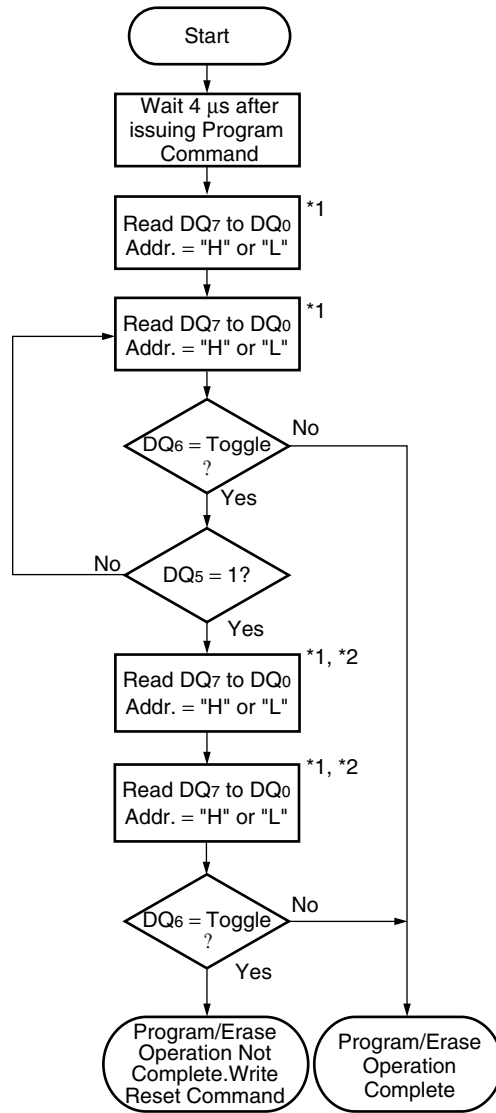

*1 : Read Toggle bit twice to determine whether it is toggling.

*2 : Recheck Toggle bit because it may stop toggling as DQ₅ changes to "1".

Toggle Bit Algorithm

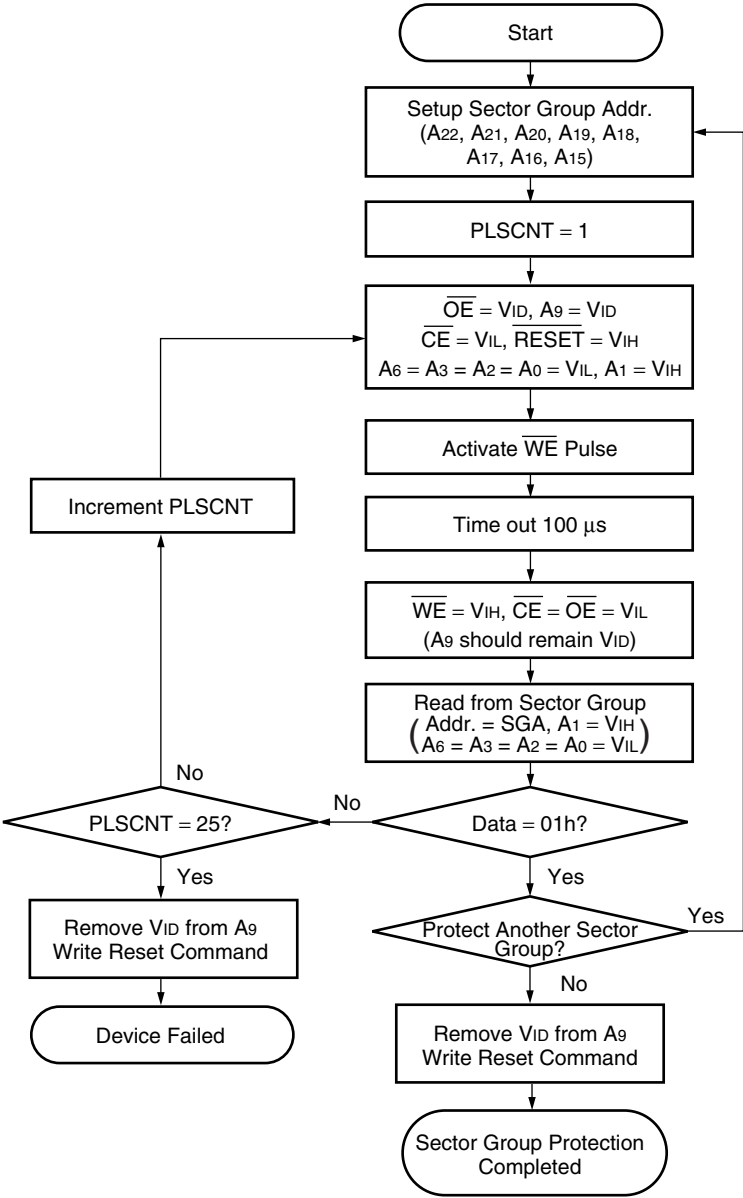

* : A-1 is V_{IL} in Byte (× 8) mode.

Sector Group Protection Algorithm

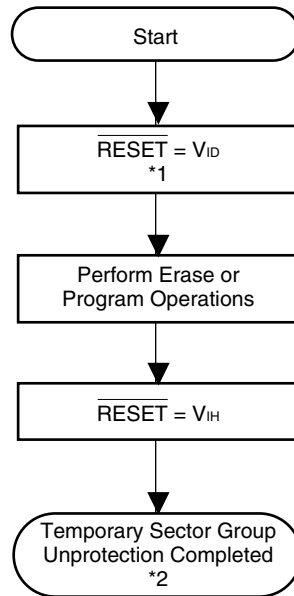

*1 : All protected sector groups are unprotected.

*2 : All previously protected sector groups are protected.

Temporary Sector Group Unprotection Algorithm

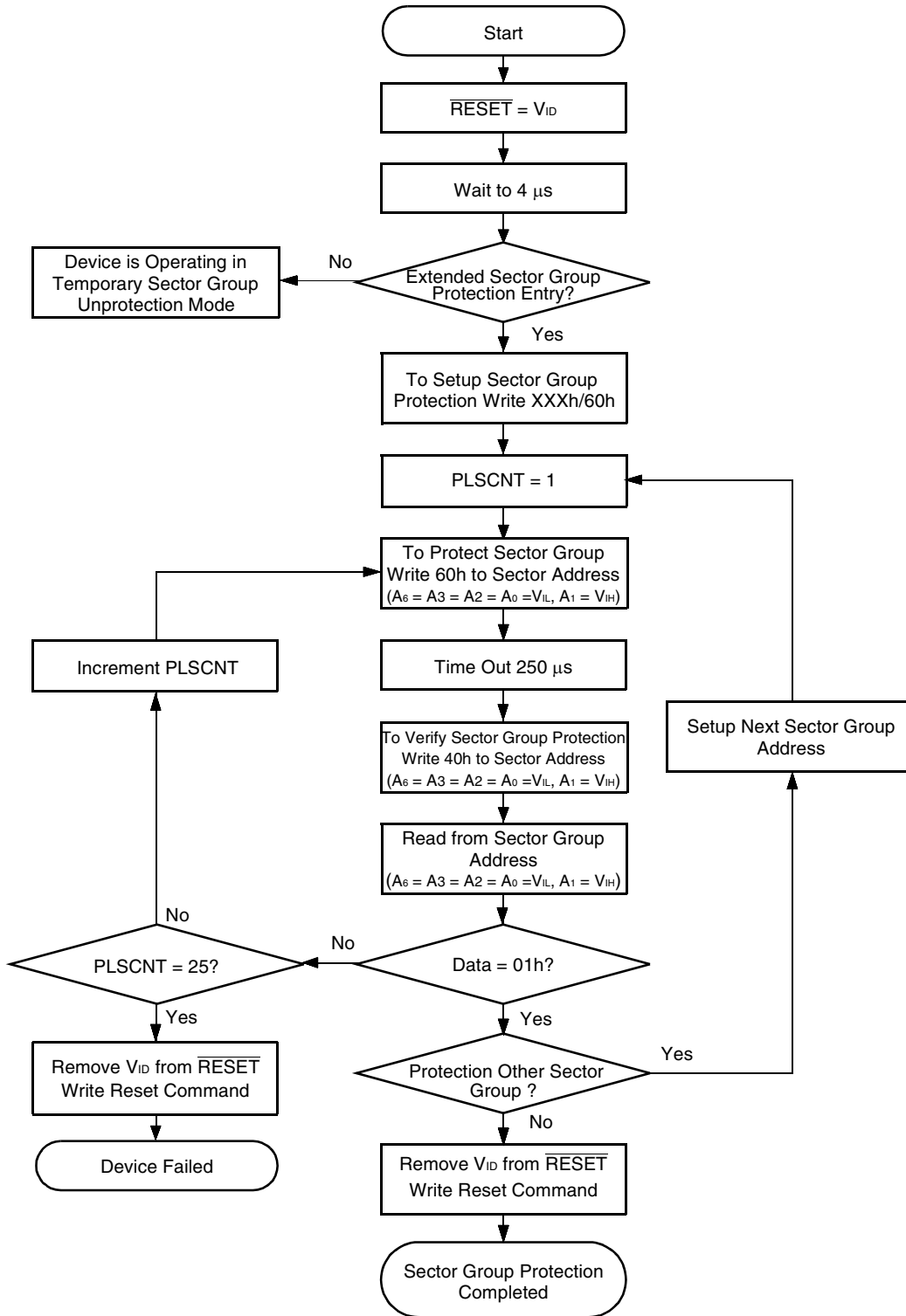

Extended Sector Group Protection Algorithm

FAST MODE ALGORITHM

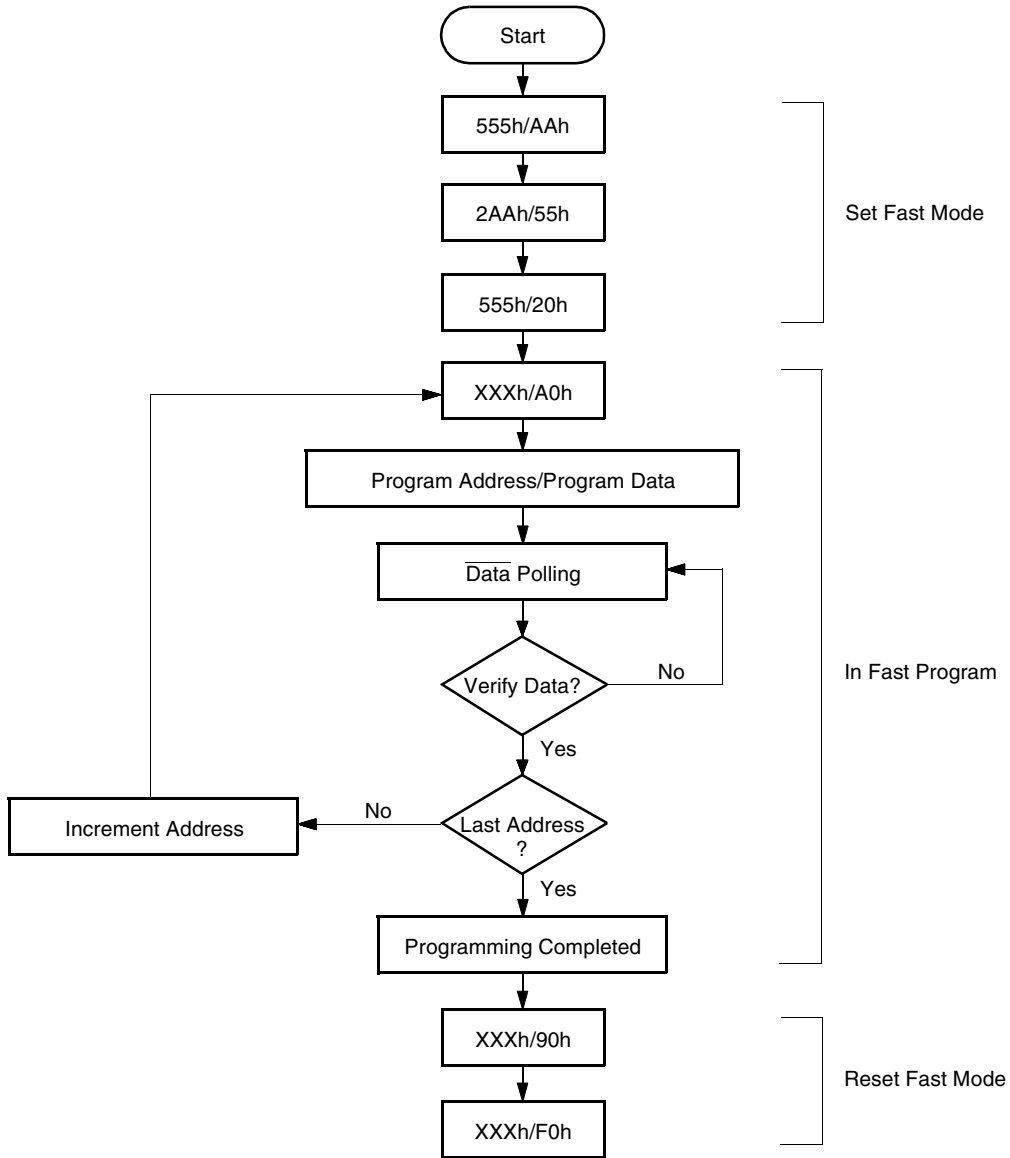

- Notes :
- The sequence is applied for Word ($\times 16$) mode.
 - The addresses differ from Byte ($\times 8$) mode.

Embedded Program™ Algorithm for Fast Mode

■ ORDERING INFORMATION

Part No.	Package	Access Time	Remarks
MBM29PL12LM10PCN	56-pin, plastic TSOP (1) (FPT-56P-M01) (Normal Bend)	100 ns	
MBM29PL12LM10PBT	80-ball, plastic FBGA (BGA-80P-M02)	100 ns	

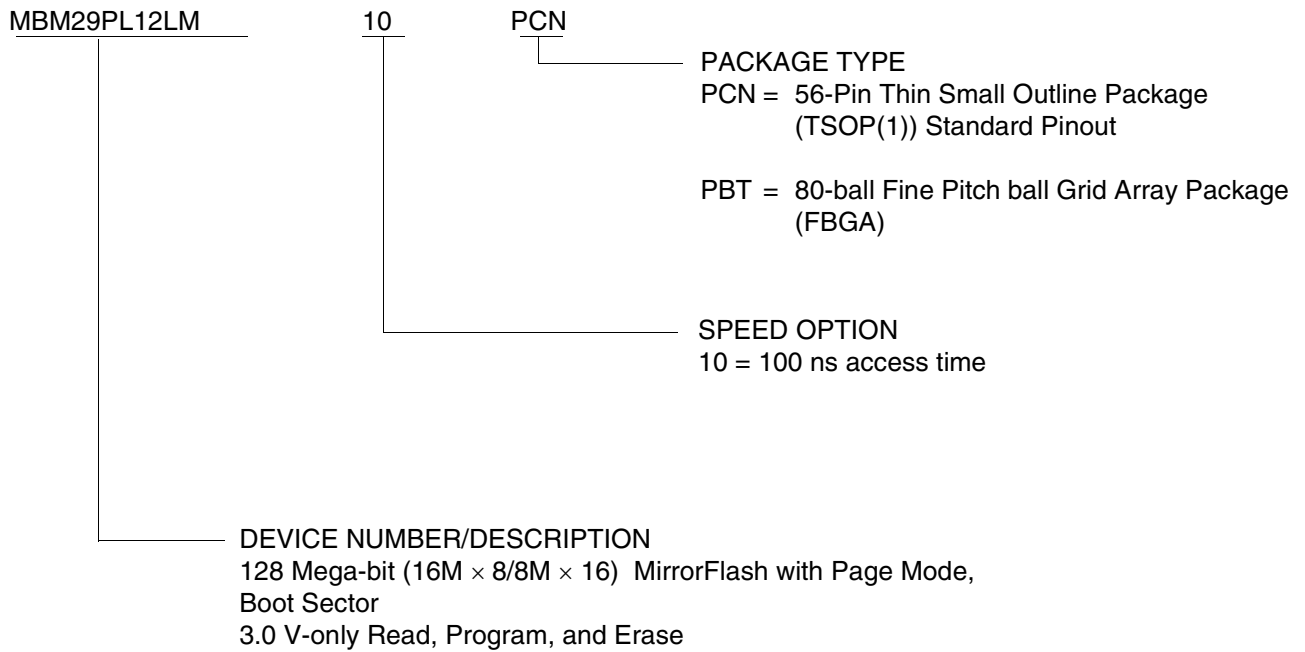

MBM29PL12LM₁₀

■ PACKAGE DIMENSIONS

56-pin plastic TSOP(1)
(FPT-56P-M01)

Note 1) *1 : Resin protrusion. (Each side : +0.15 (.006) Max) .
 Note 2) *2 : These dimensions do not include resin protrusion.
 Note 3) Pins width and pins thickness include plating thickness.
 Note 4) Pins width do not include tie bar cutting remainder.

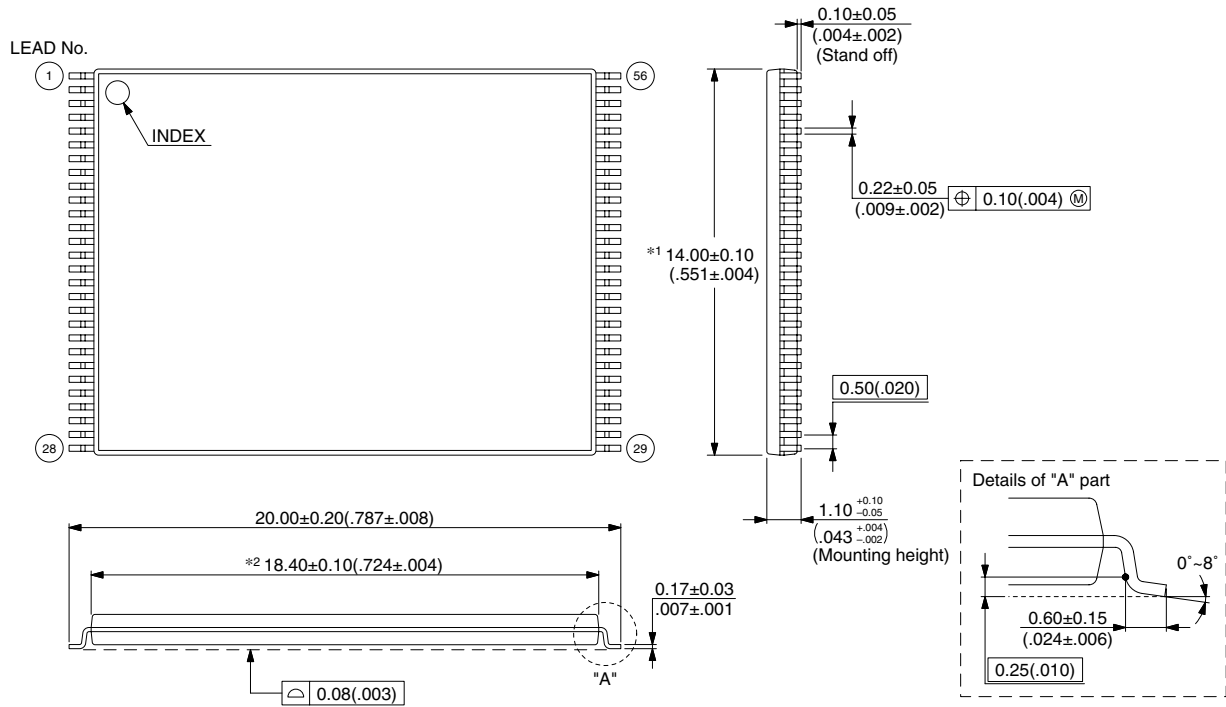

© 2002 FUJITSU LIMITED F56001S-c-4-5

Dimensions in mm (inches).

Note : The values in parentheses are reference values.

(Continued)

MBM29PL12LM₁₀

(Continued)

80-ball, plastic FBGA
(BGA-80P-M02)

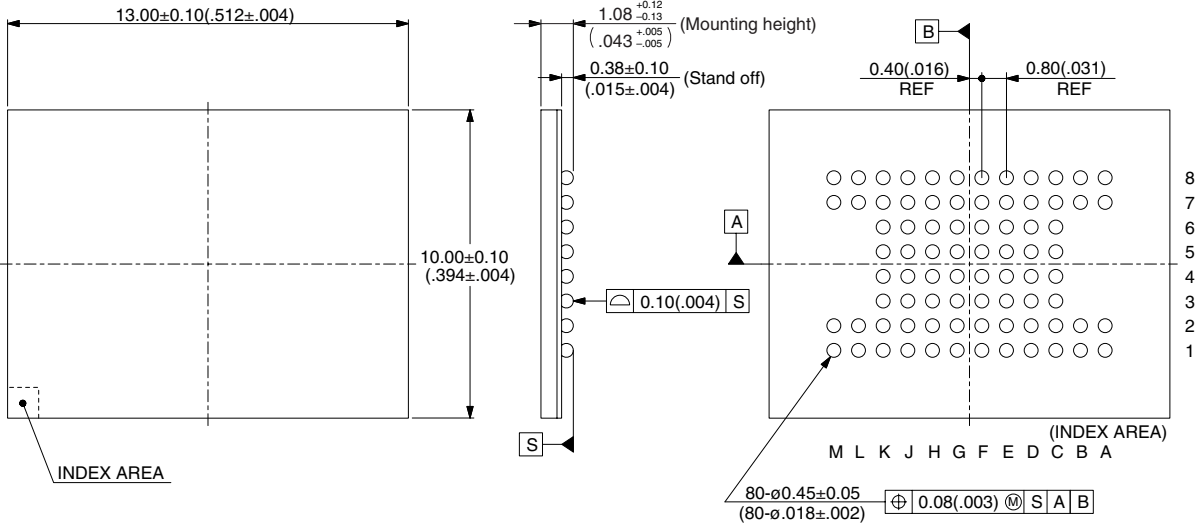

© 2003 FUJITSU LIMITED B80002S-c-1-1

Dimensions in mm (inches).
Note : The values in parentheses are reference values.

FUJITSU LIMITED

For further information please contact:

Japan

FUJITSU LIMITED
Marketing Division
Electronic Devices
Shinjuku Dai-Ichi Seimei Bldg. 7-1,
Nishishinjuku 2-chome, Shinjuku-ku,
Tokyo 163-0721, Japan
Tel: +81-3-5322-3353
Fax: +81-3-5322-3386
<http://edevice.fujitsu.com/>

North and South America

FUJITSU MICROELECTRONICS AMERICA, INC.
1250 E. Arques Avenue, M/S 333
Sunnyvale, CA 94088-3470, U.S.A.
Tel: +1-408-737-5600
Fax: +1-408-737-5999
<http://www.fma.fujitsu.com/>

Europe

FUJITSU MICROELECTRONICS EUROPE GmbH
Am Siebenstein 6-10,
D-63303 Dreieich-Buchsschlag,
Germany
Tel: +49-6103-690-0
Fax: +49-6103-690-122
<http://www.fme.fujitsu.com/>

Asia Pacific

FUJITSU MICROELECTRONICS ASIA PTE LTD.
#05-08, 151 Lorong Chuan,
New Tech Park,
Singapore 556741
Tel: +65-6281-0770
Fax: +65-6281-0220
<http://www.fmal.fujitsu.com/>

Korea

FUJITSU MICROELECTRONICS KOREA LTD.
1702 KOSMO TOWER, 1002 Daechi-Dong,
Kangnam-Gu, Seoul 135-280
Korea
Tel: +82-2-3484-7100
Fax: +82-2-3484-7111
<http://www.fmk.fujitsu.com/>

F0405

© FUJITSU LIMITED Printed in Japan

All Rights Reserved.

The contents of this document are subject to change without notice. Customers are advised to consult with FUJITSU sales representatives before ordering.

The information, such as descriptions of function and application circuit examples, in this document are presented solely for the purpose of reference to show examples of operations and uses of Fujitsu semiconductor device; Fujitsu does not warrant proper operation of the device with respect to use based on such information. When you develop equipment incorporating the device based on such information, you must assume any responsibility arising out of such use of the information. Fujitsu assumes no liability for any damages whatsoever arising out of the use of the information.

Any information in this document, including descriptions of function and schematic diagrams, shall not be construed as license of the use or exercise of any intellectual property right, such as patent right or copyright, or any other right of Fujitsu or any third party or does Fujitsu warrant non-infringement of any third-party's intellectual property right or other right by using such information. Fujitsu assumes no liability for any infringement of the intellectual property rights or other rights of third parties which would result from the use of information contained herein.

The products described in this document are designed, developed and manufactured as contemplated for general use, including without limitation, ordinary industrial use, general office use, personal use, and household use, but are not designed, developed and manufactured as contemplated (1) for use accompanying fatal risks or dangers that, unless extremely high safety is secured, could have a serious effect to the public, and could lead directly to death, personal injury, severe physical damage or other loss (i.e., nuclear reaction control in nuclear facility, aircraft flight control, air traffic control, mass transport control, medical life support system, missile launch control in weapon system), or (2) for use requiring extremely high reliability (i.e., submersible repeater and artificial satellite).

Please note that Fujitsu will not be liable against you and/or any third party for any claims or damages arising in connection with above-mentioned uses of the products.

Any semiconductor devices have an inherent chance of failure. You must protect against injury, damage or loss from such failures by incorporating safety design measures into your facility and equipment such as redundancy, fire protection, and prevention of over-current levels and other abnormal operating conditions.

If any products described in this document represent goods or technologies subject to certain restrictions on export under the Foreign Exchange and Foreign Trade Law of Japan, the prior authorization by Japanese government will be required for export of those products from Japan.



* D S 0 5 - 2 0 9 1 4 - 1 E *